

HL Paper 1

A cell of emf 6.0 V and negligible internal resistance is connected to three resistors as shown.

The resistors have resistance of $3.0\ \Omega$ and $6.0\ \Omega$ as shown.

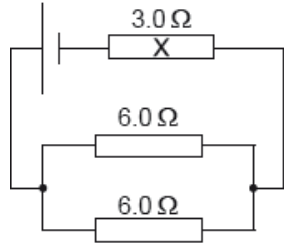

What is the current in resistor X?

- A. 0.40 A
- B. 0.50 A
- C. 1.0 A
- D. 2.0 A

Markscheme

C

Examiners report

[N/A]

A filament lamp and a semiconducting diode have the voltage–current (V – I) characteristics shown and are connected in parallel.

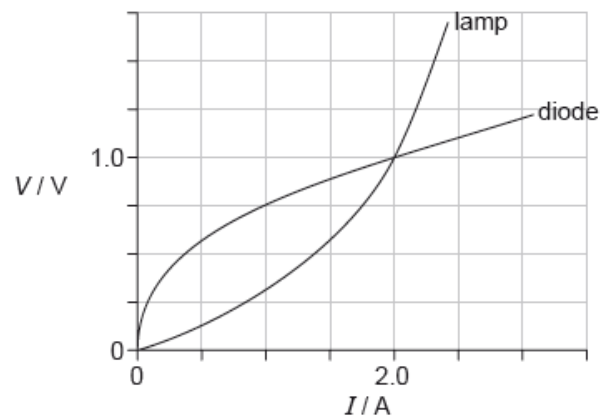

What is the resistance of the lamp and the resistance of the diode when the current in each device is 2.0 A?

	Resistance of lamp / Ω	Resistance of diode / Ω
A.	1.0	0.25
B.	1.0	0.50
C.	0.50	0.25
D.	0.50	0.50

Markscheme

D

Examiners report

[N/A]

Four point charges of magnitudes $+q$, $+q$, $-q$, and $-q$ are held in place at the corners of a square of side r .

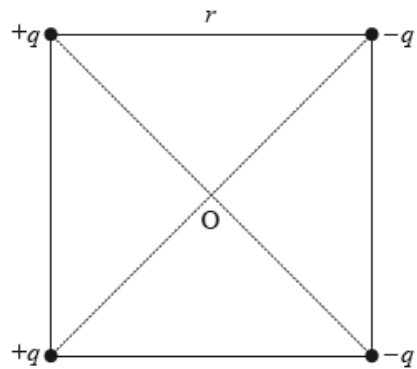

The Coulomb constant is k . Which of the following is the electrical potential at the centre of the square O?

- A. 0
- B. $\frac{4kq}{r}$
- C. $\frac{4kq\sqrt{2}}{r}$
- D. $\frac{-4kq\sqrt{2}}{r^2}$

Markscheme

A

Examiners report

[N/A]

When an electric cell of negligible internal resistance is connected to a resistor of resistance $4R$, the power dissipated in the resistor is P .

What is the power dissipated in a resistor of resistance value R when it is connected to the same cell?

- A. $\frac{P}{4}$
- B. P
- C. $4P$
- D. $16P$

Markscheme

C

Examiners report

[N/A]

A circuit is formed by connecting a resistor between the terminals of a battery of electromotive force (emf) 6 V . The battery has internal resistance.

Which statement is correct when 1 C of charge flows around the complete circuit?

- A. 6 V is the potential difference across the resistor.
- B. 6 J of thermal energy is dissipated in the battery.
- C. 6 J of chemical energy is transformed in the battery.
- D. 6 J of thermal energy is dissipated in the resistor.

Markscheme

C

Examiners report

[N/A]

An ion of charge $+Q$ moves vertically upwards through a small distance s in a uniform vertical electric field. The electric field has a strength E and its direction is shown in the diagram.

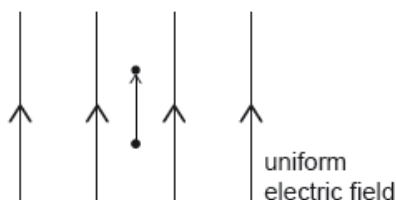

What is the electric potential difference between the initial and final position of the ion?

- A. $\frac{EQ}{s}$
 B. EQs
 C. Es
 D. $\frac{E}{s}$

Markscheme

C

Examiners report

[N/A]

A 12V battery has an internal resistance of 2.0Ω . A load of variable resistance is connected across the battery and adjusted to have resistance equal to that of the internal resistance of the battery. Which statement is correct for this circuit?

- A. The current in the battery is 6A.
 B. The potential difference across the load is 12V.
 C. The power dissipated in the battery is 18W.
 D. The resistance in the circuit is 1.0Ω .

Markscheme

C

Examiners report

[N/A]

A proton p is at rest between the poles of two horizontal magnets as shown below.

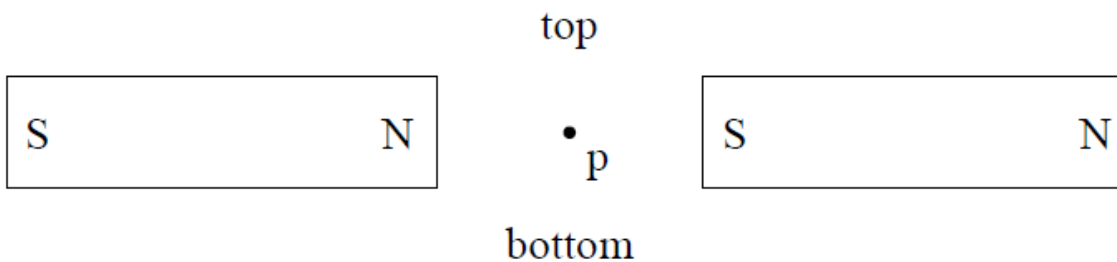

The magnetic force on the proton is

- A. from left to right.
 B. from top to bottom.
 C. into the plane of the paper.

Markscheme

D

Examiners report

[N/A]

The diagram shows the path of a particle in a region of uniform magnetic field. The field is directed into the plane of the page.

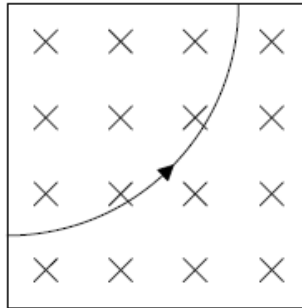

This particle could be

- A. an alpha particle.
- B. a beta particle.
- C. a photon.
- D. a neutron.

Markscheme

A

Examiners report

[N/A]

A current carrying wire is in the same plane as a uniform magnetic field. The angle between the wire and the magnetic field is θ .

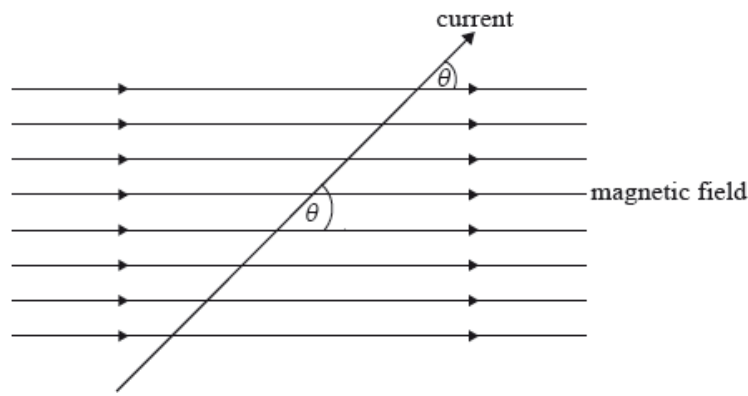

The magnetic force on the current carrying wire is

- A. zero.
- B. into the plane of the paper.
- C. out of the plane of the paper.
- D. at an angle θ to the direction of the magnetic field.

Markscheme

B

Examiners report

[N/A]

Electrons, each with a charge e , move with speed v along a metal wire. The electric current in the wire is I .

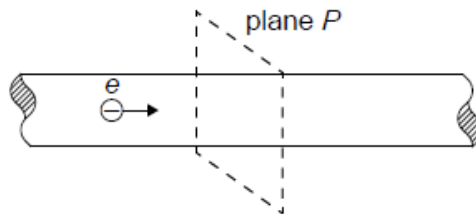

Plane P is perpendicular to the wire. How many electrons pass through plane P in each second?

- A. $\frac{e}{I}$
- B. $\frac{ve}{I}$
- C. $\frac{I}{ve}$
- D. $\frac{I}{e}$

Markscheme

D

Examiners report

An ion follows a circular path in a uniform magnetic field. Which single change decreases the radius of the path?

- A. Increasing the mass of the ion
- B. Increasing the charge of the ion
- C. Increasing the speed of the ion
- D. Decreasing the magnetic flux density of the field

Markscheme

B

Examiners report

[N/A]

A resistor has a resistance R . The potential difference across the resistor is V . Which of the following gives the energy dissipated in the resistor in time t ?

- A. $\frac{Vt}{R}$
- B. $\frac{Rt}{V^2}$
- C. RV^2t
- D. $\frac{V^2t}{R}$

Markscheme

D

Examiners report

[N/A]

The electric potential is V_R at a point R in an electric field and at another point S the electric potential is V_S . Which of the following is the work done by the electric field on a point charge $+q$ as it moves from R to S?

- A. $V_R - V_S$

B. $q(V_R - V_S)$

C. $V_S - V_R$ D. $q(V_S - V_R)$

Markscheme

B

Examiners report

This question stem needed careful reading. The discrimination index of 0.00 showed that even the better candidates were jumping to conclusions.

When work is done, it must be stated clearly what it is that is doing the work, and on what. So if a weight is being lifted, then the lifter is doing (positive) work against the field, which means that the field is doing negative work on the ball. This needs to be clearly spelt out to candidates. In this case there is a charge moving in an electrical field and the candidates are being invited to state the work done by the field on the charge.

Two wires, X and Y, are made from the same metal. The wires are connected in series. The radius of X is twice that of Y. The carrier drift speed in X is v_X and in Y it is v_Y .

What is the value of the ratio $\frac{v_X}{v_Y}$?

A. 0.25

B. 0.50

C. 2.00

D. 4.00

Markscheme

A

Examiners report

[N/A]

A copper wire with length L and radius r has a resistance R .

What is the radius of a copper wire with length $\frac{L}{2}$ and resistance R ?

B. $\sqrt{2}r$

C. $\frac{r}{\sqrt{2}}$

D. $\frac{r}{2}$

Markscheme

C

Examiners report

[N/A]

Positive charge is uniformly distributed on a semi-circular plastic rod. What is the direction of the electric field strength at point S?

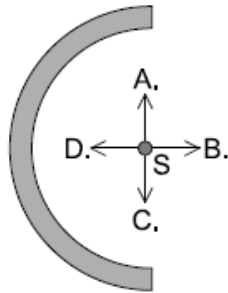

Markscheme

B

Examiners report

[N/A]

Two resistors, of resistance R_1 and R_2 , are connected in series with a cell of emf ε and negligible internal resistance.

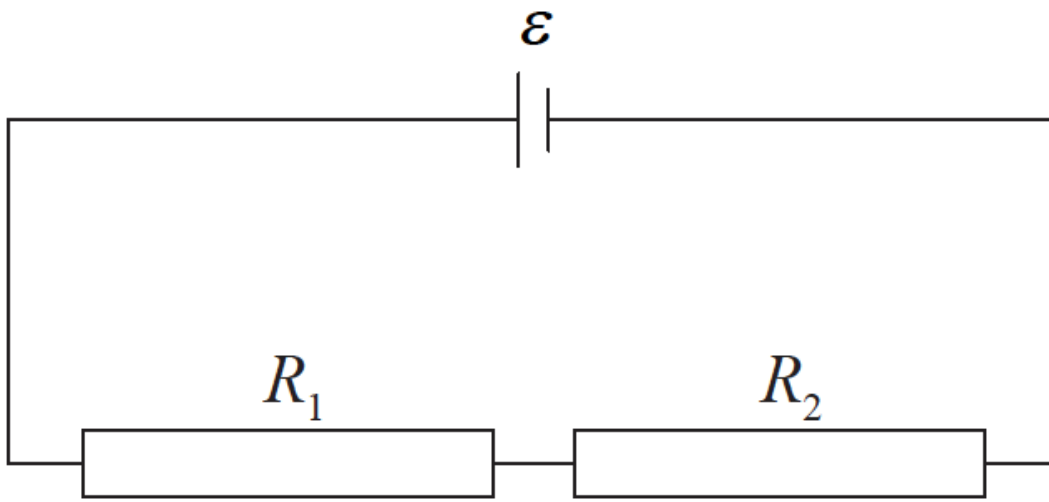

Which expression gives the potential difference across the resistor of resistance R_1 ?

- A. $\left(\frac{R_1}{R_1+R_2}\right) \epsilon$
- B. $\left(\frac{R_1+R_2}{R_1}\right) \epsilon$
- C. $\left(\frac{R_2}{R_1+R_2}\right) \epsilon$
- D. $\left(\frac{R_1+R_2}{R_2}\right) \epsilon$

Markscheme

A

Examiners report

A voltmeter of resistance $50\text{k}\Omega$ is used to measure the electric potential difference in a circuit, as shown. The cell has an electromotive force (emf) of 5.0V and negligible internal resistance.

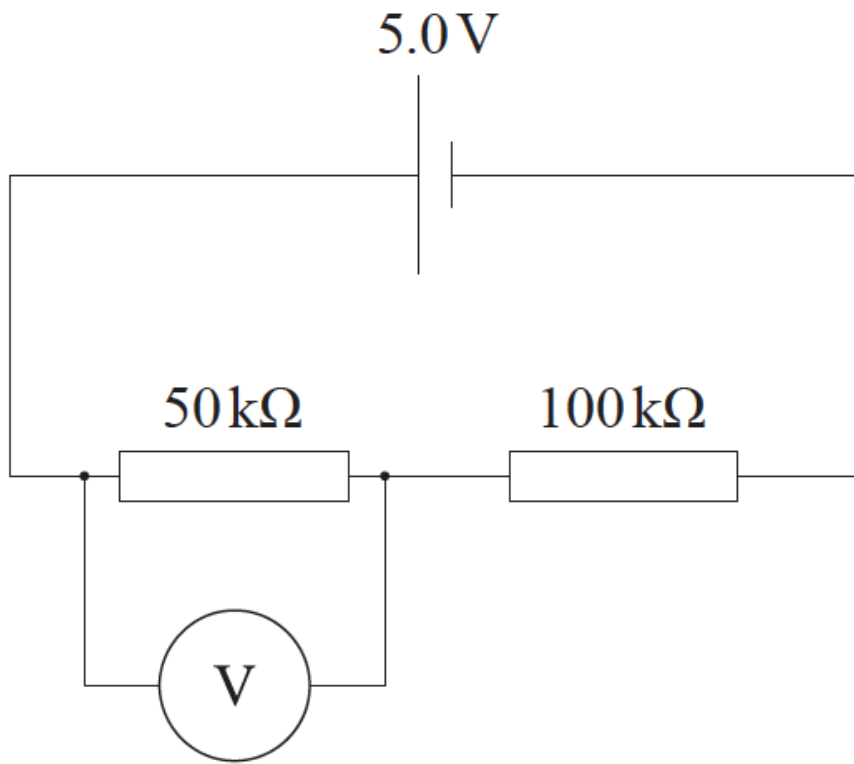

What is the reading on the voltmeter?

- A. 1.0 V
- B. 1.7 V
- C. 4.0 V
- D. 5.0 V

Markscheme

A

Examiners report

This should have been a straightforward question but many candidates opted for B. This highlights the importance of carefully reading the question. Candidates must not assume that all relevant information will be on the diagram.

A positively charged particle follows a circular path as shown below.



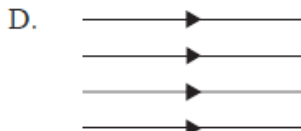
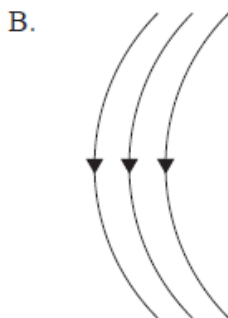
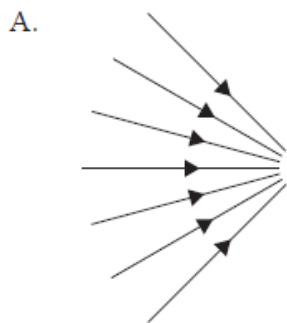

Markscheme

A

Examiners report

[N/A]

A metal rod M is falling vertically within a horizontal magnetic field. The metal rod and magnetic field are directed into the paper. What is the direction of the initial force acting on the metal rod that is predicted by Lenz's law?

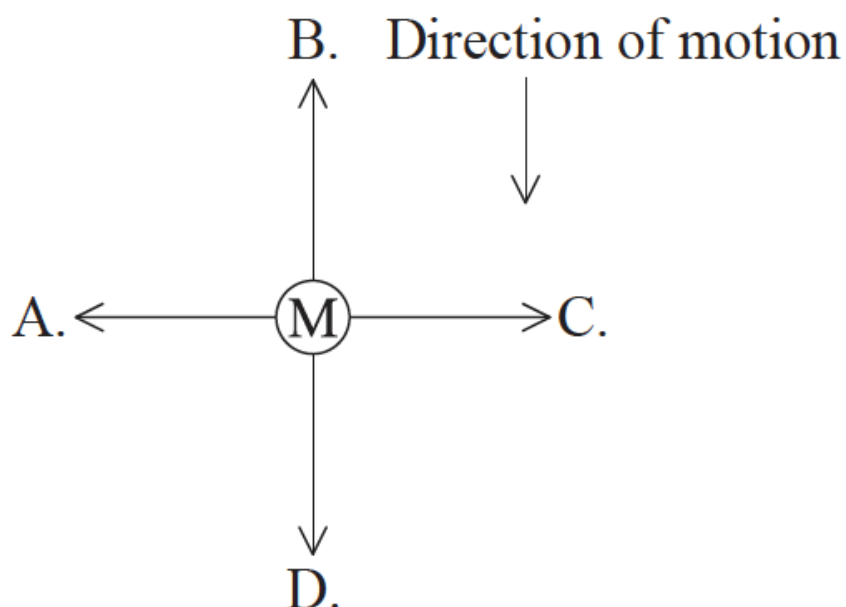

Examiners report

The correct response here is B. As the rod falls, an electric current is induced, forcing the electrons across the diameter of the wire. This in turn, produces an upward force on the rod as a whole in line with Lenz's Law.

A circuit consists of a cell of electromotive force (emf) 6.0V and negligible internal resistance connected to two resistors of 4.0Ω.

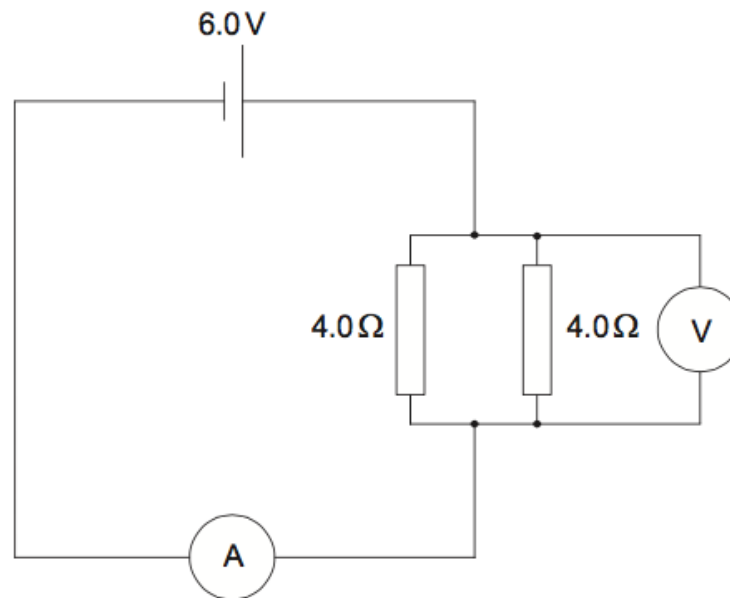

The ammeter has resistance equal to 1.0Ω and the voltmeter is ideal. What are the readings of the ammeter and the voltmeter?

	Ammeter	Voltmeter
A.	2.0A	3.0V
B.	3.0A	3.0V
C.	2.0A	4.0V
D.	3.0A	4.0V

Markscheme

Examiners report

Two isolated point charges, $-7\mu\text{C}$ and $+2\mu\text{C}$, are at a fixed distance apart. At which point is it possible for the electric field strength to be zero?

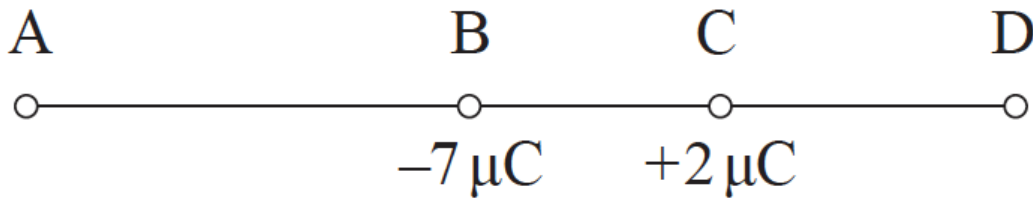

(not to scale)

Markscheme

D

Examiners report

An ideal ammeter is used to measure the current in a resistor. Which of the following gives the resistance of an ideal ammeter and the way it is connected to the resistor?

	Resistance	Connection
A.	infinite	in parallel
B.	infinite	in series
C.	zero	in parallel
D.	zero	in series

Markscheme

@TOPhysicsTutor

facebook.com/TheOnlinePhysicsTutor

Examiners report

[N/A]

The diagram below shows a uniform electric field of strength E . The field is in a vacuum.

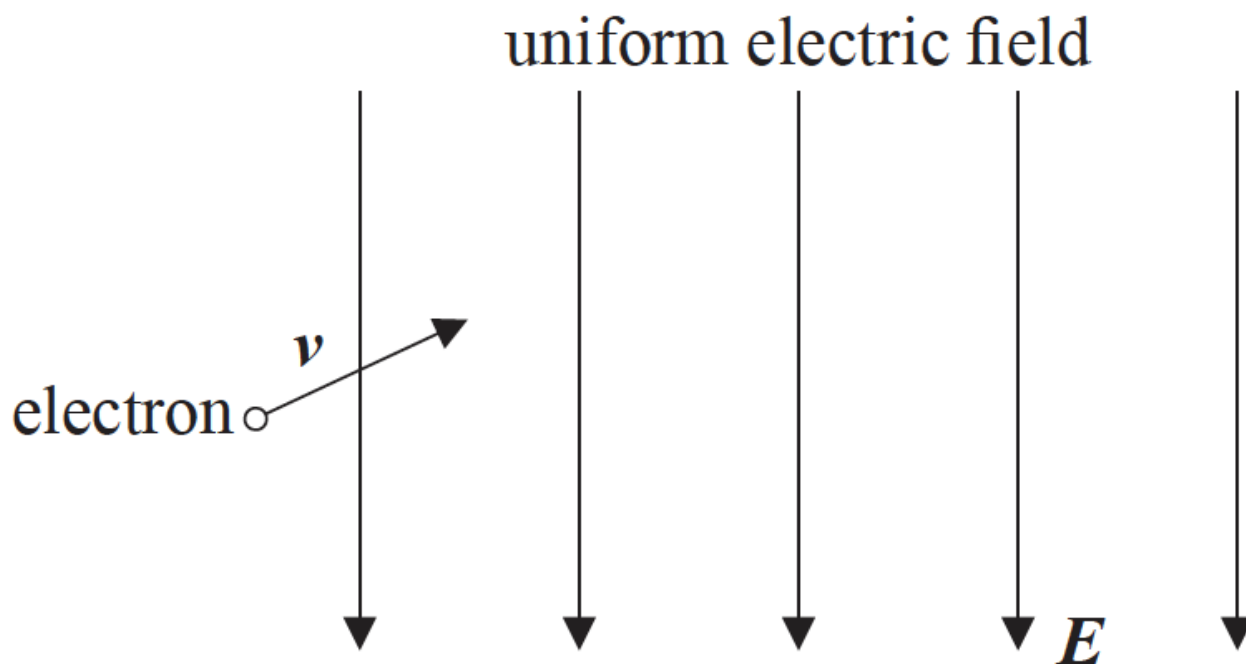

An electron enters the field with a velocity v in the direction shown. The electron is moving in the plane of the paper. The path followed by the electron will be

- A. parabolic.
- B. in the direction of E .
- C. in the direction of v .
- D. circular.

Markscheme

A

Examiners report

A long straight wire carries an electric current perpendicularly out of the paper. Which of the following represents the magnetic field pattern due to the current?

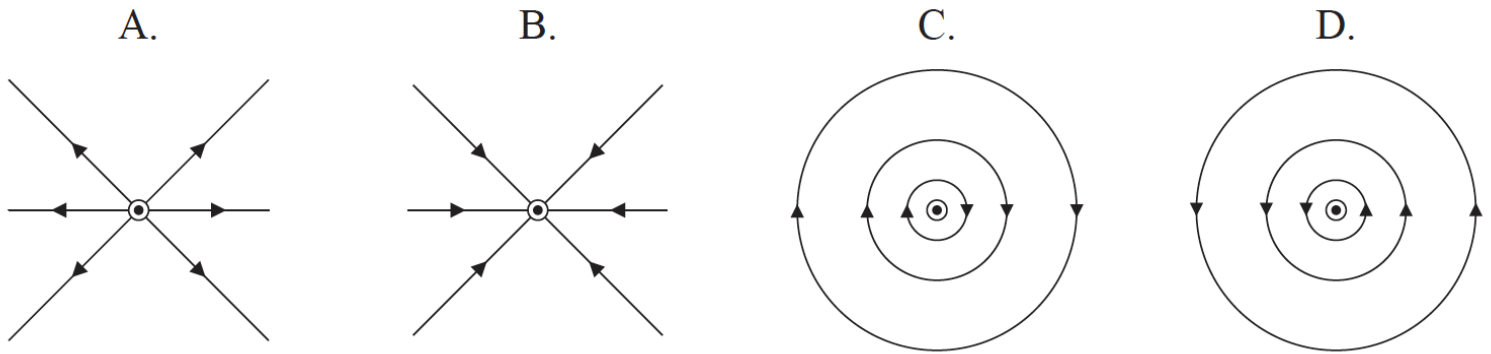

Markscheme

D

Examiners report

The diagram shows the magnetic field surrounding two current-carrying metal wires P and Q. The wires are parallel to each other and at right angles to the plane of the page.

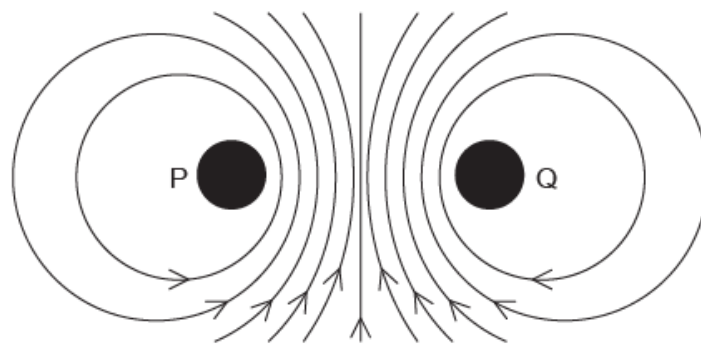

What is the direction of the electron flow in P and the direction of the electron flow in Q?

	Direction of electron flow in P	Direction of electron flow in Q
A.	into page	into page
B.	into page	out of page
C.	out of page	into page
D.	out of page	out of page

B

Examiners report

[N/A]

A lamp is connected to an electric cell and it lights at its working voltage. The lamp is then connected to the same cell in a circuit with an ideal ammeter and an ideal voltmeter. Which circuit allows the lamp to light at the original brightness?

A.

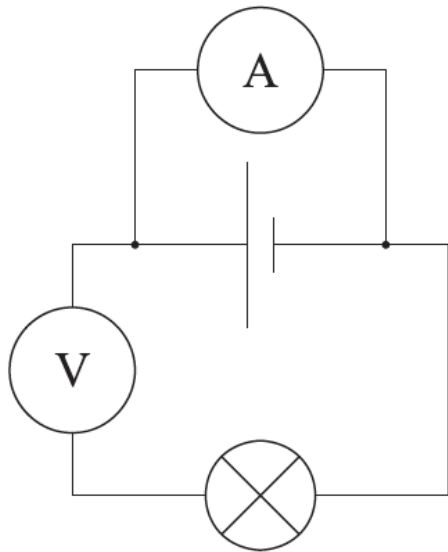

B.

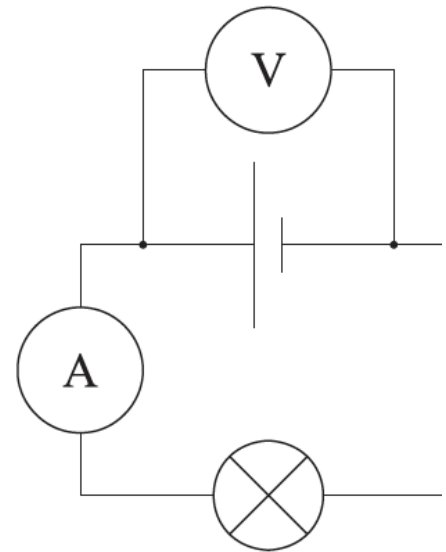

C.

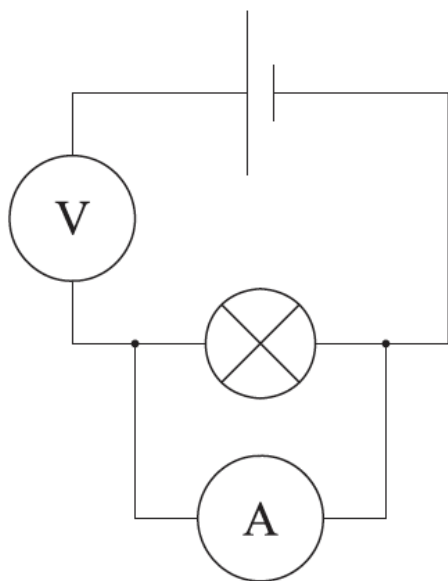

D.

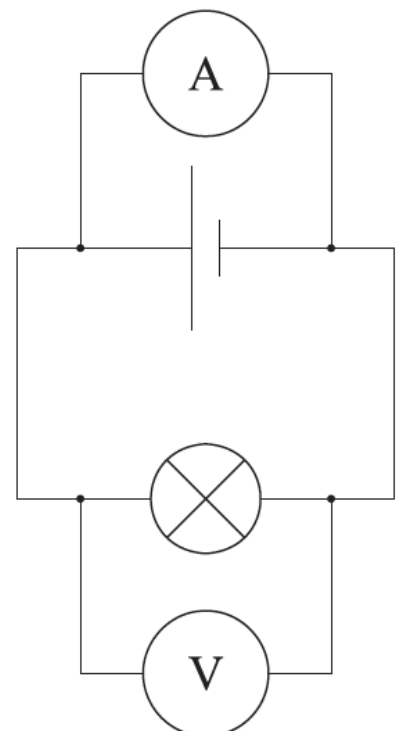

B

Examiners report

[N/A]

The diagram shows an electric circuit containing a potentiometer of maximum resistance R . The potentiometer is connected in series with a resistor also of resistance R . The electromotive force (emf) of the battery is 6 V and its internal resistance is negligible.

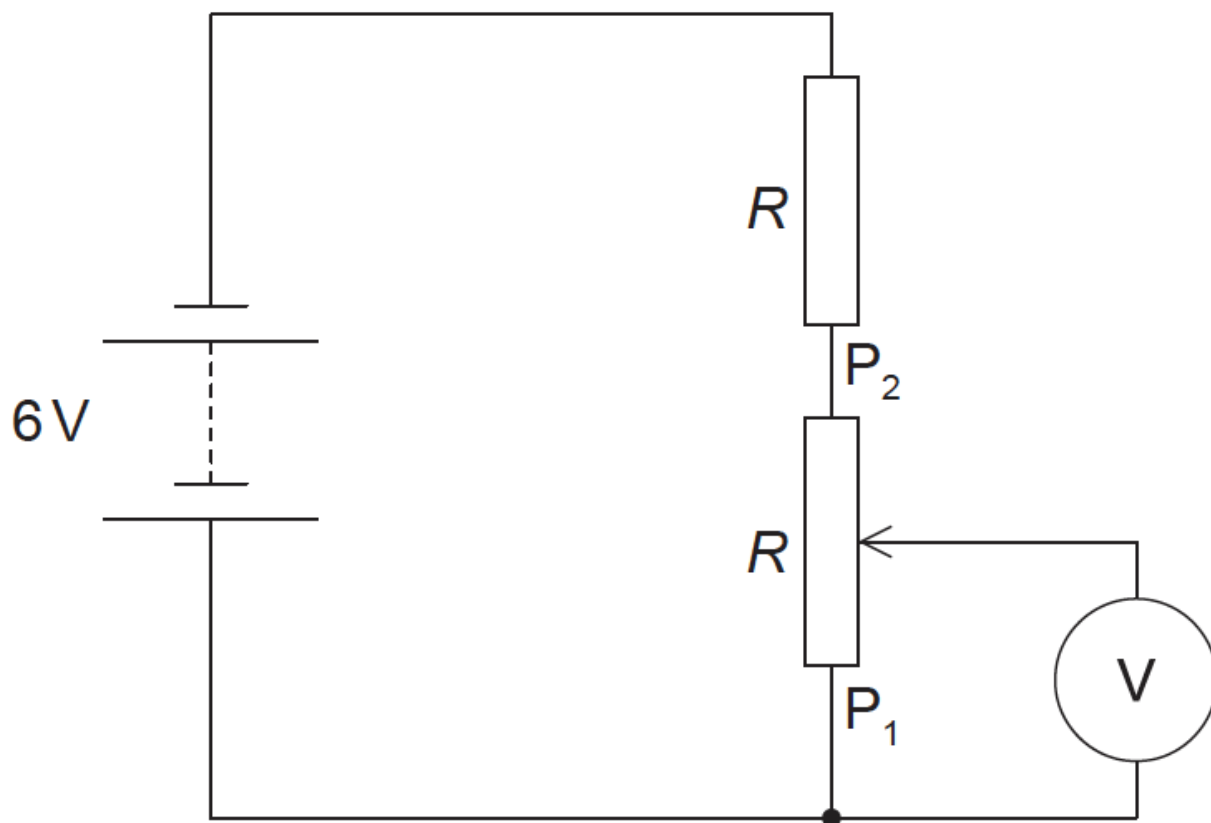

The slider on the potentiometer is moved from P_1 to P_2 . Which graph shows the variation of the voltmeter V reading with slider distance d ?

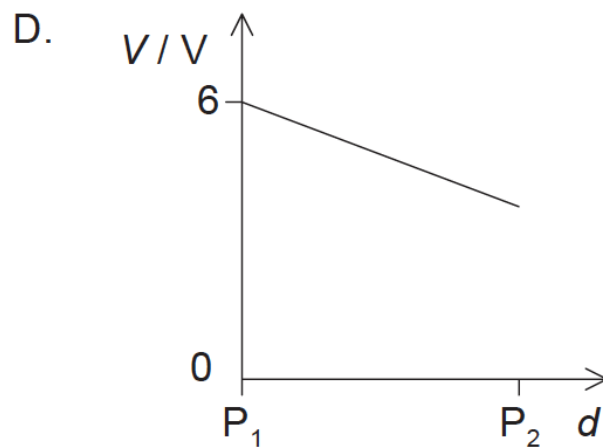
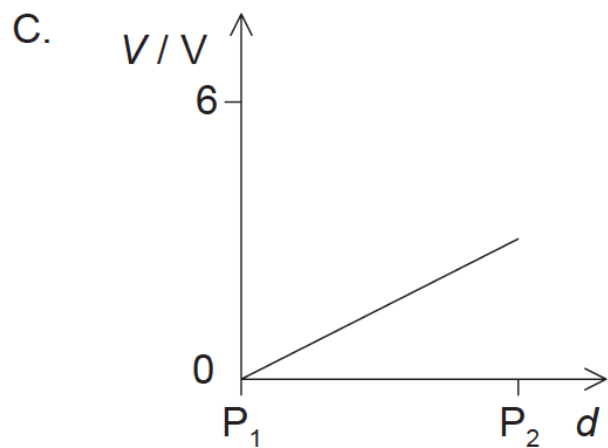
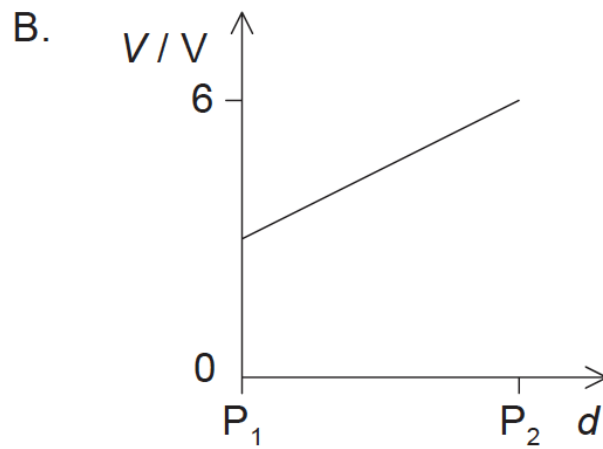
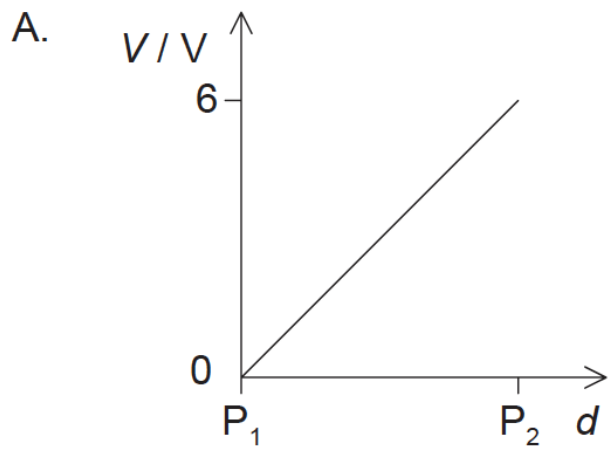

Markscheme

C

Examiners report

[N/A]
