

SL Paper 2

This question is in **two** parts. **Part 1** is about kinematics and Newton's laws of motion.

Part 2 is about electrical circuits.

Part 1 Kinematics and Newton's laws of motion

Cars I and B are on a straight race track. I is moving at a constant speed of 45 m s^{-1} and B is initially at rest. As I passes B, B starts to move with an acceleration of 3.2 m s^{-2} .

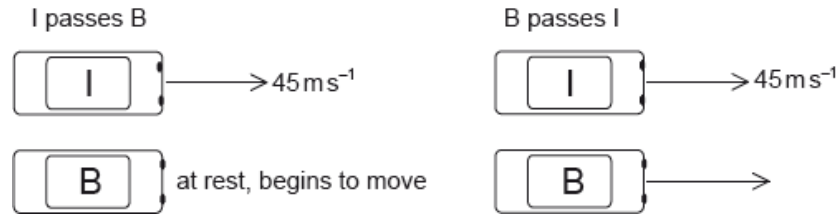

At a later time B passes I. You may assume that both cars are point particles.

A third car O with mass 930 kg joins the race. O collides with I from behind, moving along the same straight line as I. Before the collision the speed of I is 45 m s^{-1} and its mass is 850 kg . After the collision, I and O stick together and move in a straight line with an initial combined speed of 52 m s^{-1} .

This question is in **two** parts. **Part 1** is about kinematics and Newton's laws of motion.

Part 2 Electrical circuits

The circuit shown is used to investigate how the power developed by a cell varies when the load resistance R changes.

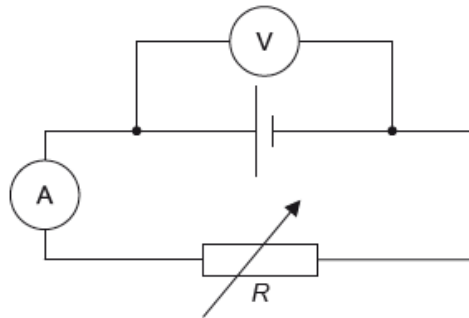

The variable resistor is adjusted and a series of current and voltage readings are taken. The graph shows the variation with R of the power dissipated in the cell and the power dissipated in the variable resistor.

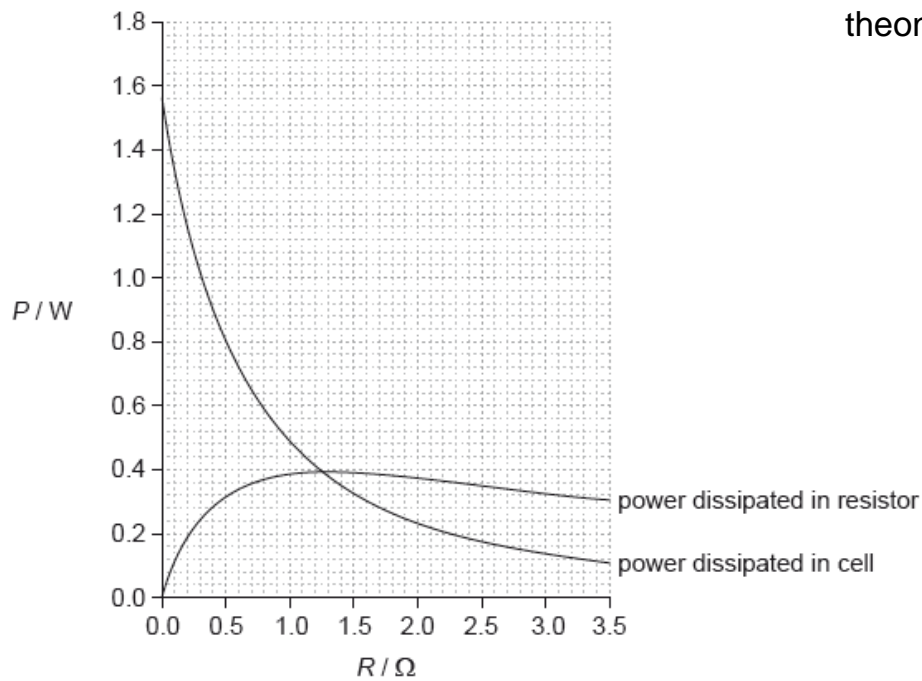

The cell has an internal resistance.

- a.i. Show that the time taken for B to pass I is approximately 28 s. [4]
- a.ii. Calculate the distance travelled by B in this time. [2]
- b. B slows down while I remains at a constant speed. The driver in each car wears a seat belt. Using Newton's laws of motion, explain the difference in the tension in the seat belts of the two cars. [3]
- c.i. Calculate the speed of O immediately before the collision. [2]
- c.ii. The duration of the collision is 0.45 s. Determine the average force acting on O. [2]
- d. An ammeter and a voltmeter are used to investigate the characteristics of a variable resistor of resistance R . State how the resistance of the ammeter and of the voltmeter compare to R so that the readings of the instruments are reliable. [2]
- e. Show that the current in the circuit is approximately 0.70 A when $R = 0.80 \Omega$. [3]
- f.i. Outline what is meant by the internal resistance of a cell. [2]
- f.ii. Determine the internal resistance of the cell. [3]
- g. Calculate the electromotive force (emf) of the cell. [2]

Markscheme

a.i. distances itemized; (*it must be clear through use of s_I or distance I etc*)

distances equated;

$$t = \frac{2v}{a} / \text{cancel and re-arrange;}$$

@TOPhysicsTutor substitution: $(\frac{2 \times 45}{2})$, shown / 28.1(s) seen;

or

clear written statement that the average speed of B must be the same as constant speed of I;

as B starts from rest the final speed must be 2×45 ;

$$\text{so } t = \frac{\Delta v}{a} = \frac{90}{3.2};$$

28.1 (s) seen; (*for this alternative the method must be clearly described*)

or

attempts to compare distance travelled by I and B for 28 s;

I distance = $(45 \times 28 =) 1260$ (m);

B distance = $(\frac{1}{2} \times 3.2 \times 28^2 =) 1255$ (m);

deduces that overtake must occur about $(\frac{5}{45} =) 0.1$ s later;

a.ii. use of appropriate equation of motion;

$(1.26 \approx) 1.3$ (km);

Award [2] for a bald correct answer.

b. driver I moves at constant speed so no net (extra) force according to Newton 1;

driver B decelerating so (extra) force (to rear of car) (according to Newton 1) / momentum/inertia change so (extra) force must be present;

(hence) greater tension in belt B than belt I;

Award [0] for stating that tension is less in the decelerating car (B).

c.i. $930 \times v + 850 \times 45 = 1780 \times 52$ **or** statement that momentum is conserved;

$$v = 58 \text{ (m s}^{-1}\text{)};$$

Allow [2] for a bald correct answer.

c.ii. use of force $\frac{\text{change of momentum}}{\text{time}}$ (or any variant, eg: $\frac{930 \times 6.4}{0.45}$);

13.2×10^3 (N); } (*must see matched units and value ie: 13 200 without unit gains MP2, 13.2 does not*)

Award [2] for a bald correct answer.

Allow use of 58 m s^{-1} from (c)(i) to give 12 400 (N).

d. ammeter must have very low resistance/much smaller than R ;

voltmeter must have very large resistance/much larger than R ;

Allow [1 max] for zero and infinite resistance for ammeter and voltmeter respectively.

Allow [1 max] if superlative (eg: very/much/OWTTE) is missing.

e. power (loss in resistor) = 0.36 (W); } (*accept answers in the range of 0.35 to 0.37 (W) – treat value outside this range as ECF (could still lead to*

0.7))

$$I^2 \times 0.80 = 0.36;$$

$$I = 0.67 \text{ (A) or } \sqrt{\left(\frac{0.36}{0.8}\right)}; \text{ } \textit{(allow answers in the range of 0.66 to 0.68 (A).)}$$

f.i. resistance of the components/chemicals/materials within the cell itself; } (*not "resistance of cell"*)

leading to energy/power loss in the cell;

f.ii. power (in cell with 0.7 A) = 0.58 W; } (*allow answers in the range of 0.57 W to 0.62 W*)

$$0.7^2 \times r = 0.58;$$

$$r = 1.2 \text{ } (\Omega); \text{ (allow answers in the range of 1.18 to 1.27 } (\Omega))$$

or

when powers are equal;

$$I^2 R = I^2 r;$$

so $r = R$ which occurs at 1.2(5) (Ω);

Award **[1 max]** for bald 1.2(5) (Ω).

g. $(E = I(R + r)) = 0.7(0.8 + 1.2);$

$$1.4 \text{ (V)};$$

Allow ECF from (e) or (f)(ii).

or

when $R = 0$, power loss = 1.55;

$$E = (\sqrt{1.55 \times 1.2} =) 1.4 \text{ (V)};$$

Examiners report

a.i. [N/A]

a.ii. [N/A]

b. [N/A]

c.i. [N/A]

c.ii. [N/A]

d. [N/A]

e. [N/A]

f.i. [N/A]

f.ii. [N/A]

g. [N/A]

In 1997 a high-speed car of mass 1.1×10^4 kg achieved the world land speed record. The car accelerated uniformly in two stages as shown in the table. The car started from rest.

	Time / s	Speed attained at end of stage / m s^{-1}
Stage 1	0.0 – 4.0	44
Stage 2	4.0 – 12	280

Use the data to calculate the

a. average acceleration of the car in stage 1. [1]

b. average net force required to accelerate the car in stage 2. [3]

c. total distance travelled by the car in 12 s. [2]

Markscheme

b. $\Delta v = 236$;

$$a = \left(\frac{236}{8} \right) = 29.5 \text{ (m s}^{-2}\text{)};$$

$$(F = 1.1 \times 10^4 \times 29.5) = 3.2 \times 10^5 \text{ N};$$

Award **[2 max]** for omission of initial speed (answer is 390 kN).

Award **[3]** for correct bald answer.

c. phase 1 distance 88 m / phase 2 distance 1296 m;

total 1400 m;

Award **[2]** for correct bald answer.

Watch for significant figure penalty in this question (1384 m).

Award **[1 max]** for $\frac{1}{2}at^2$ substituted correctly for first phase, if no distances

evaluated and answer incorrect.

Award **[1 max]** for correct addition of incorrect phase 1 and/or 2 distance(s).

Examiners report

a. Most candidates were able to score well on this part.

b. There were widespread failures to achieve the correct intermediate step of evaluating the acceleration in stage 2. The initial speed was often taken to be zero.

c. This very simple part caused problems for many who were unable to calculate the distances travelled in each stage, or add these together correctly.

Part 2 Momentum

b. State the law of conservation of momentum. [2]

c. Far from any massive object, a space rocket is moving with constant velocity. The engines of the space rocket are turned on and it accelerates [3]
by burning fuel and ejecting gases. Discuss how the law of conservation of momentum relates to this situation.

d. Jane and Joe are two ice skaters initially at rest on a horizontal skating rink. They are facing each other and Jane is holding a ball. Jane throws [4]
the ball to Joe who catches it. The speed at which the ball leaves Jane, measured relative to the ground, is 8.0 m s^{-1} .

The following data are available.

Mass of Jane = 52 kg

Mass of Joe = 74 kg

Mass of ball = 1.3 kg

Use the data to calculate the

speed of the ball relative to the ground immediately after she throws the ball.

Markscheme

- b. if the net external force acting on a system is zero;

the momentum of the system remains constant/unchanged/the same;

or

for a closed system;

the momentum remains constant/unchanged/the same;

Award [1] for "momentum before collision equals momentum after collision".

Do not accept "momentum is conserved".

- c. identifies the system as rocket + exhaust gases / total momentum of rocket and gas is equal before and after; (*it must be clear that this is the*

system, a mention of rocket and gases is not enough)

no external forces act on this system / closed system;

increase/change in momentum of the gases is equal and opposite to the increase/change of momentum of the rocket;

- d. (i) attempts to use conservation of momentum, eg $8.0 \times 1.3 = 52 \times v$;

$$v = 0.20(\text{ms}^{-1});$$

Award [2] for a bald correct answer.

(ii) identifies new mass as 75.3(kg);

$$V = 0.14(\text{ms}^{-1});$$

Examiners report

- b. A common error re-emerged in this examination. If asked to state a law of conservation a candidate must *not* simply say that the "quantity is conserved". This tells the examiner nothing (other than that the candidate has read the question) and will never attract marks. This is a simple examination skill that many candidates continue to fail to learn.

- c. Few were able to give adequate discussions of the how momentum conservation applies to one of the most common cases discussed in teaching at this level, that of a rocket in free space. There was no clear recognition that the system is closed or even what the system is or that the important factor is the *change* in momentum of the fuel and therefore the rocket. These are difficult ideas for candidates to grasp but examiners expected better attempts from the most able.

- d. (i) This was well done.

(ii) About one-third of candidates failed to recognise that the mass of Joe needs to have the mass of the ball added to it for a correct solution of the problem

This question is in **two** parts. **Part 1** is about the motion of a car. **Part 2** is about electricity.

A car is travelling along the straight horizontal road at its maximum speed of 56 m s^{-1} . The power output required at the wheels is 0.13 MW .

A driver moves the car in a horizontal circular path of radius 200 m . Each of the four tyres will not grip the road if the frictional force between a tyre and the road becomes less than 1500 N .

Part 2 Electricity

A lemon can be used to make an electric cell by pushing a copper rod and a zinc rod into the lemon.

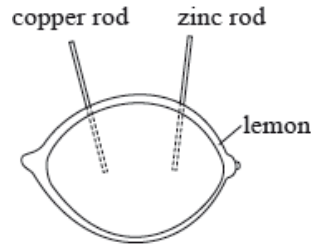

A student constructs a lemon cell and connects it in an electrical circuit with a variable resistor. The student measures the potential difference V across the lemon and the current I in the lemon.

- a. A car accelerates uniformly along a straight horizontal road from an initial speed of 12 m s^{-1} to a final speed of 28 m s^{-1} in a distance of 250 m . The mass of the car is 1200 kg . Determine the rate at which the engine is supplying kinetic energy to the car as it accelerates. [4]
- b. A car is travelling along a straight horizontal road at its maximum speed of 56 m s^{-1} . The power output required at the wheels is 0.13 MW . [5]
- Calculate the total resistive force acting on the car when it is travelling at a constant speed of 56 m s^{-1} .
 - The mass of the car is 1200 kg . The resistive force F is related to the speed v by $F \propto v^2$. Using your answer to (b)(i), determine the maximum theoretical acceleration of the car at a speed of 28 m s^{-1} .
- c. (i) Calculate the maximum speed of the car at which it can continue to move in the circular path. Assume that the radius of the path is the same for each tyre. [6]
- While the car is travelling around the circle, the people in the car have the sensation that they are being thrown outwards. Outline how Newton's first law of motion accounts for this sensation.
- d. (i) Draw a circuit diagram of the experimental arrangement that will enable the student to collect the data for the graph. [10]
- Show that the potential difference V across the lemon is given by

$$V = E - Ir$$
 where E is the emf of the lemon cell and r is the internal resistance of the lemon cell.
 - The graph shows how V varies with I .

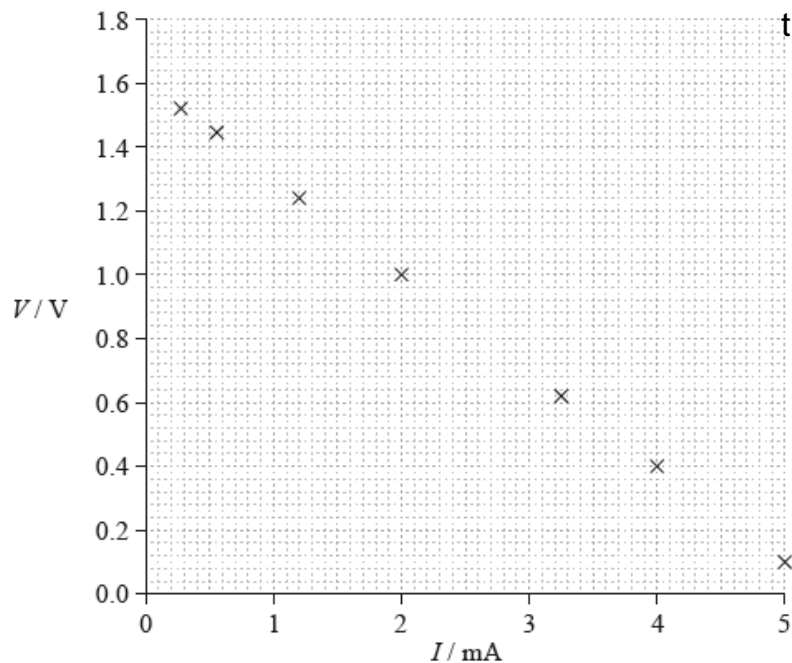

Using the graph, estimate the emf of the lemon cell.

(iv) Determine the internal resistance of the lemon cell.

(v) The lemon cell is used to supply energy to a digital clock that requires a current of $6.0 \mu\text{A}$. The clock runs for 16 hours. Calculate the charge that flows through the clock in this time.

Markscheme

a. use of a kinematic equation to determine motion time (= 12.5 s);

$$\text{change in kinetic energy} = \frac{1}{2} \times 1200 \times [28^2 - 12^2] \quad (= 384 \text{ kJ});$$

$$\text{rate of change in kinetic energy} = \frac{384000}{12.5}; \quad \text{\{allow ECF of 162 from } (28 - 12)^2 \text{ for this mark}\}}$$

31 (kW);

or

use of a kinematic equation to determine motion time (= 12.5 s);

use of a kinematic equation to determine acceleration (= 1.28 m s^{-2});

$$\text{work done} = \frac{F \times s}{\text{time}} = \frac{1536 \times 250}{12.5};$$

31 (kW);

b. (i) force = $\frac{\text{power}}{\text{speed}}$;

2300 **or** 2.3k (N);

Award [2] for a bald correct answer.

(ii) resistive force = $\frac{2300}{4}$ **or** $\frac{2321}{4}$ (= 575); (allow ECF)

so accelerating force = (2300 – 580 =) 1725 (N) **or** 1741 (N);

$$a = \frac{1725}{1200} = 1.44 \text{ (ms}^{-2}\text{)} \quad \text{or} \quad a = \frac{1741}{1200} = 1.45 \text{ (ms}^{-2}\text{)};$$

Award [2 max] for an answer of 0.49 (ms⁻²) (omits 2300 N).

c. (i) centripetal force must be < 6000 (N); (allow force = 6000 N)

$$v^2 = F \times \frac{r}{m};$$

$$21.6 \text{ (ms}^{-1}\text{)};$$

Allow [3] for a bald correct answer.

Allow [2 max] if $4 \times$ is omitted, giving $15.8 \text{ (m s}^{-1}\text{)}$.

(ii) statement of Newton's first law;

(hence) without car wall/restraint/friction at seat, the people in the car would move in a straight line/at a tangent to circle;

(hence) seat/seat belt/door exerts centripetal force;

(in frame of reference of the people) straight ahead movement is interpreted as "outwards";

d. (i) voltmeter in parallel with cell; (allow ammeter within voltmeter leads)

ammeter in series with variable resistor; } (must draw as variable arrangement or as potential divider)

Allow cell symbol for lemon/cell/box labelled "lemon cell".

Award [1 max] if additional cell appears in the circuit.

(ii) $E = I(R + r)$ and $V = IR$ used; (must state both explicitly)

re-arrangement correct ie $E = V + Ir$; } (accept any other correct re-arrangement eg. involving energy conversion)

(iii) line correctly extrapolated to y -axis; (judge by eye)

1.6 or 1.60 (V); (allow ECF from incorrect extrapolation)

(iv) correct read-offs from large triangle greater than half line length;

gradient determined;

290 to 310 (Ω);

Award [2 max] for the use of one point on line and equation.

(v) 0.35 (C);

Examiners report

a. There were at least two routes to tackle this problem. Some solutions were so confused that it was difficult to decide which method had been used. Common errors included: forgetting that the initial speed was 12 m s^{-1} not zero, power of ten errors, and simple mistakes in the use of the kinematic equations, or failure to evaluate work done = force \times distance correctly. However, many candidates scored partial credit. Scores of two or three out of the maximum four were common showing that many are persevering to get as far as they can.

b. (i) Many correct solutions were seen. Candidates are clearly comfortable with the use of the equation force = power/speed.

(ii) The method to be used here was obvious to many. What was missing was a clear appreciation of what was happening in terms of resistive force in the system. Many scored two out of three because they indicated a sensible method but did not use the correct value for the force. Scoring two marks does require that the explanation of the method is at least competent. Those candidates who give limited explanations of their method leading to a wrong answer will generally accumulate little credit. A suggestion (never seen in answers) is that candidates should have begun from a free-body force diagram which would have revealed the relationship of all the forces.

c. (i) The major problem here was that most candidates did not recognise that 1500 N of force acting at each of four wheels will imply a total force of 6 kN. Again, partial credit was available only if it was clear what the candidate was doing and what the error was.

(ii) Statements of Newton's first law were surprisingly poor. As in previous examinations, few candidates appear to have learnt this essential rule by heart and they produce a garbled and incomplete version under examination pressure. The first law was then only loosely connected to the particular context of the question. Candidates have apparently not learnt to relate the physics they learn to everyday contexts.

d. (i) Circuit diagrams continue to be a particular issue for many candidates. Neat, well-drawn diagrams are rarely seen. Some diagrams had two cells, the lemon cell and another. Variable resistors were sometimes absent (or were drawn as fixed). Potential dividers were often attempted

usually unsuccessfully. Generally candidates gained an average one mark for what should have been a familiar task.

- (ii) Those who quoted the data booklet equation and the definition of resistance were generally able to show the correct answer, but could not convince the examiners that they knew what they were doing.
- (iii) Candidates were expected to understand the physical point that the emf can be determined when the current in the cell is zero. For many, an extrapolation of the obvious straight line to the emf axis and a correct read-off gave an easy couple of marks. Some however did not understand the physics of the circuit and gave poorly described solutions.
- (iv) The internal resistance was best obtained from a large triangle drawn on the graph. Many however gained two of the three marks because they engendered power of ten errors or because they used only one point, or because their triangle was too small.
- (v) Only a minority were able to use the data to calculate the charge transferred correctly.

A small ball of mass m is moving in a horizontal circle on the inside surface of a frictionless hemispherical bowl.

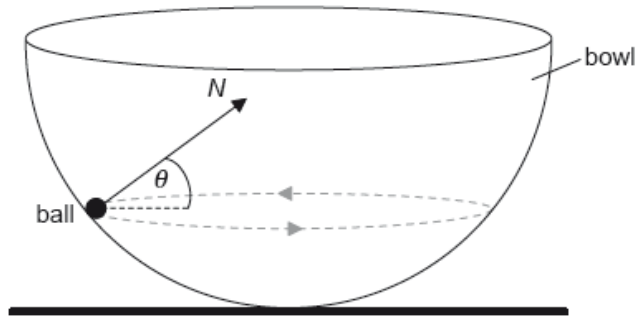

The normal reaction force N makes an angle θ to the horizontal.

a.i. State the direction of the resultant force on the ball.

[1]

a.ii. On the diagram, construct an arrow of the correct length to represent the weight of the ball.

[2]

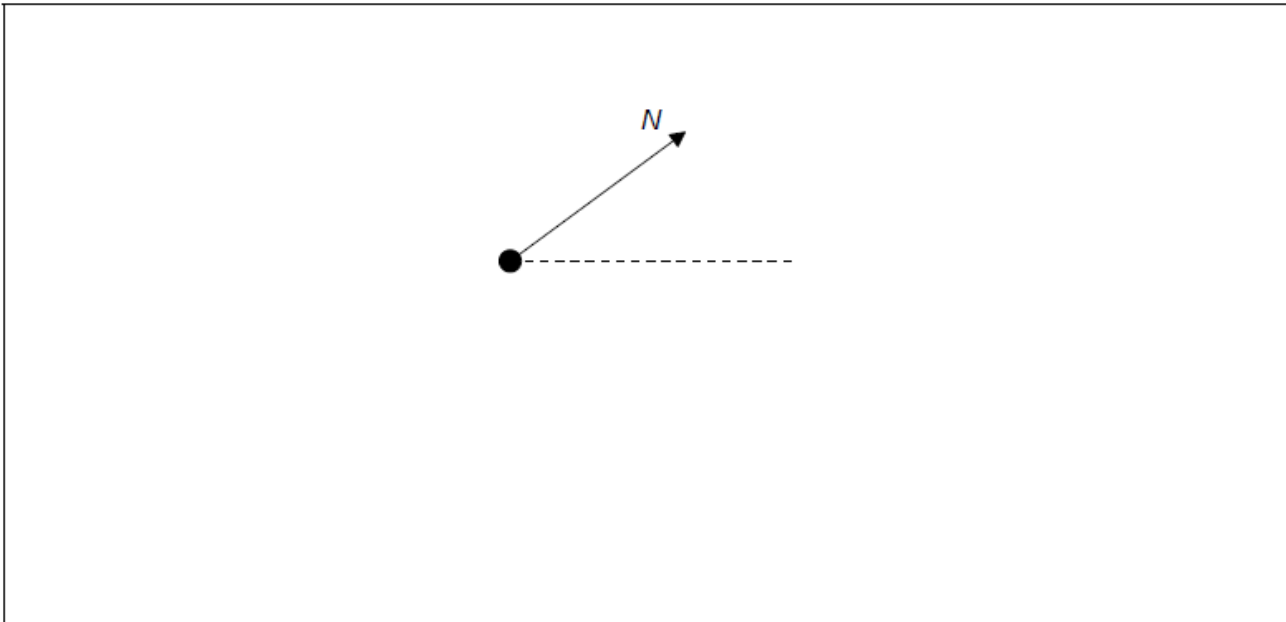

a.iii. Show that the magnitude of the net force F on the ball is given by the following equation.

[3]

$$F = \frac{mg}{\tan \theta}$$

b. The radius of the bowl is 8.0 m and $\theta = 22^\circ$. Determine the speed of the ball.

[4]

c. Outline whether this ball can move on a horizontal circular path of radius equal to the radius of the bowl.

d. A second identical ball is placed at the bottom of the bowl and the first ball is displaced so that its height from the horizontal is equal to 8.0 m. [3]

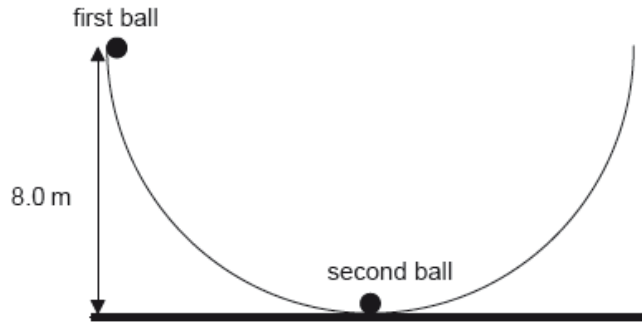

The first ball is released and eventually strikes the second ball. The two balls remain in contact. Determine, in m, the maximum height reached by the two balls.

Markscheme

a.i. towards the centre «of the circle» / horizontally to the right

Do not accept towards the centre of the bowl

[1 mark]

a.ii. downward vertical arrow of any length

arrow of correct length

Judge the length of the vertical arrow by eye. The construction lines are not required. A label is not required

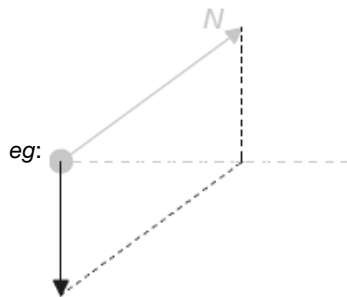

[2 marks]

a.iii **ALTERNATIVE 1**

$$F = N \cos \theta$$

$$mg = N \sin \theta$$

dividing/substituting to get result

ALTERNATIVE 2

right angle triangle drawn with F , N and W/mg labelled

angle correctly labelled and arrows on forces in correct directions

correct use of trigonometry leading to the required relationship

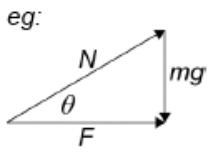

$$\tan \theta = \frac{O}{A} = \frac{mg}{F}$$

[3 marks]

b. $\frac{mg}{\tan \theta} = m \frac{v^2}{r}$

$$r = R \cos \theta$$

$$v = \sqrt{\frac{gR \cos^2 \theta}{\sin \theta}} / \sqrt{\frac{gR \cos \theta}{\tan \theta}} / \sqrt{\frac{9.81 \times 8.0 \cos 22}{\tan 22}}$$

$$v = 13.4/13 \text{ «ms}^{-1}\text{»}$$

Award **[4]** for a bald correct answer

Award **[3]** for an answer of 13.9/14 «ms⁻¹». MP2 omitted

[4 marks]

c. there is no force to balance the weight/N is horizontal

so no / it is not possible

Must see correct justification to award MP2

[2 marks]

d. speed before collision $v = \sqrt{2gR} \Rightarrow 12.5 \text{ «ms}^{-1}\text{»}$

«from conservation of momentum» common speed after collision is $\frac{1}{2}$ initial speed « $v_c = \frac{12.5}{2} = 6.25 \text{ ms}^{-1}$ »

$$h = \frac{v_c^2}{2g} = \frac{6.25^2}{2 \times 9.81} \approx 2.0 \text{ «m»}$$

Allow 12.5 from incorrect use of kinematics equations

Award **[3]** for a bald correct answer

Award **[0]** for $mg(\theta) = 2mgh$ leading to $h = 4 \text{ m}$ if done in one step.

Allow ECF from MP1

Allow ECF from MP2

[3 marks]

Examiners report

a.i. [N/A]

a.ii. [N/A]

a.iii. [N/A]

b. [N/A]

c. [N/A]

d. [N/A]

This question is about the use of energy resources.

Electrical energy is obtained from tidal energy at La Rance in France.

Water flows into a river basin from the sea for six hours and then flows from the basin back to the sea for another six hours. The water flows through turbines and generates energy during both flows.

The following data are available.

$$\text{Area of river basin} = 22 \text{ km}^2$$

$$\text{Change in water level of basin over six hours} = 6.0 \text{ m}$$

$$\text{Density of water} = 1000 \text{ kg m}^{-3}$$

Nuclear reactors are used to generate energy. In a particular nuclear reactor, neutrons collide elastically with carbon-12 nuclei ($^{12}_6\text{C}$) that act as the moderator of the reactor. A neutron with an initial speed of $9.8 \times 10^6 \text{ m s}^{-1}$ collides head-on with a stationary carbon-12 nucleus. Immediately after the collision the carbon-12 nucleus has a speed of $1.5 \times 10^6 \text{ m s}^{-1}$.

- a. State the difference between renewable and non-renewable energy sources. [1]
- b. (i) The basin empties over a six hour period. Show that about 6000 m^3 of water flows through the turbines every second. [10]
- (ii) Show that the average power that the water can supply over the six hour period is about 0.2 GW.
- (iii) La Rance tidal power station has an energy output of $5.4 \times 10^8 \text{ kW h}$ per year. Calculate the overall efficiency of the power station. Assume that the water can supply 0.2 GW at all times.
- Energy resources such as La Rance tidal power station could replace the use of fossil fuels. This may result in an increase in the average albedo of Earth.
- (iv) State **two** reasons why the albedo of Earth must be given as an average value.
- d. (i) State the principle of conservation of momentum. [10]
- (ii) Show that the speed of the neutron immediately after the collision is about $8.0 \times 10^6 \text{ m s}^{-1}$.
- (iii) Show that the fractional change in energy of the neutron as a result of the collision is about 0.3.
- (iv) Estimate the minimum number of collisions required for the neutron to reduce its initial energy by a factor of 10^6 .
- (v) Outline why the reduction in energy is necessary for this type of reactor to function.

Markscheme

- a. only non-renewable is depleted/cannot re-generate whereas renewable can / consumption rate of non-renewables is greater than formation rate and consumption rate of renewables is less than formation rate;

Do not allow "cannot be used again".

- b. (i) volume released = $(22 \times 10^6 \times 6) = 1.32 \times 10^8 \text{ (m}^3\text{)}$;

$$\text{volume per second} = \frac{1.32 \times 10^8}{6 \times 3600} (= 6111 \text{ m}^3\text{)}$$

- (ii) use of average depth for calculation (3 m);

$$\text{gpe lost} = 6100 \times 1000 \times 9.81 \times 3;$$

Accept $g = 10 \text{ m s}^{-2}$.

Award **[1 max]** if 6 m is used and an "average" is used at end of solution without mention of average depth.

(iii) converts/states output with units; } (allow values quoted from question without unit)

converts/states input with units; } (allow values quoted from question without unit)

calculates efficiency from $\frac{\text{output}}{\text{input}}$ as 0.31;

Award **[3]** for bald correct answer.

eg:

$$\text{power output } \frac{5.4 \times 10^8}{365 \times 24 \times 3600} \quad (= 17 \text{ kW h s}^{-1});$$

$$= 17 \times 3600000 = 6.16 \times 10^7 \text{ (W)};$$

$$\text{efficiency} = \left(\frac{6.16 \times 10^7}{2.0 \times 10^8} \right) = 31\% \text{ or } 0.31;$$

or

$$0.2 \text{ GW is } 1.752 \times 10^9 \text{ (kW h year}^{-1}\text{)};$$

$$\frac{5.4 \times 10^8}{1.752 \times 10^9};$$

$$\text{efficiency} = 0.31;$$

(iv) cloud cover / weather conditions;

latitude;

time of year / season;

nature/colour of surface;

d. (i) (total) momentum unchanged before and after collision / momentum of a system is constant; } (allow symbols if explained)

no external forces / isolated system / closed system;

Do not accept "conserved".

(ii) final momentum of neutron = neutron mass $\times 9.8 \times 10^6 - 1u \times 12 \times 1.5 \times 10^6$; } (allow any appropriate and consistent mass unit)

final speed of neutron = 8.0 **or** $8.2 \times 10^6 \text{ (m s}^{-1}\text{)};$

$$(\approx 8.0 \times 10^6 \text{ (m s}^{-1}\text{)})$$

Allow use of 1 u for both masses giving an answer of $8.2 \times 10^6 \text{ (m s}^{-1}\text{)}$.

(iii) initial energy of neutron = $8.04 \times 10^{-14} \text{ (J)}$ and final energy of neutron = $5.36 \times 10^{-14} \text{ (J)}$; } (both needed)

$$\text{fractional change in energy} = \left(\frac{8.04 - 5.36}{8.04} \right) = 0.33;$$

or

$$\text{fractional change} = \left(\frac{\frac{1}{2}mv_1^2 - \frac{1}{2}mv_2^2}{\frac{1}{2}mv_1^2} \right); \text{ } \} \text{(allow any algebra that shows a subtraction of initial term from final term divided by initial value)}$$

$$\left(= \frac{(9.8 \times 10^6)^2 - (8.0 \times 10^6)^2}{(9.8 \times 10^6)^2} \right) \text{ (allow omission of } 10^6\text{)}$$

$$= 0.33; \text{ (allow } 0.30 \text{ if } 8.2 \text{ used)}$$

Do not allow ECF if there is no subtraction of energies in first marking point.

$$(iv) (0.33)^n = 10^{-6};$$

$$n = 13; \text{ (allow } n = 12 \text{ if } 0.3 \text{ is used)}$$

(v) neutrons produced in fission have large energies;

greatest probability of (further) fission/absorption (when incident neutrons have thermal energy or low energy);

Do not accept "reaction" for "fission reaction".

- a. Many candidates continue to give weak responses to questions in which they are asked to compare renewable and non-renewable resources.
- Although the “it cannot be used again” answer has largely disappeared, many candidates still fail to appreciate that the issue is about the rate at which the resource can be replaced.
- b. (i) This was often well done, although occasional recourse was made to inappropriate physics (see bii). Candidates should note that in questions where the final answer is quoted (typically “Show that” questions) candidates are strongly advised to quote answers to one more significant figure than in the question.
- (ii) The rare candidate who understood the physics here was able to give a clear account of the solution. Many failed to spot the factor of a half in the water level change and introduced a factor of two later and arbitrarily. Others completely misunderstood the (simple) nature of the problem and used a random equation from the data booklet (usually $1/3\rho Av^3$). This of course gained no marks. A simple initial diagram would have helped many to avoid errors.
- (iii) As in question 1 there were far too many candidates who clearly do not understand and have not practised the problem of converting between energy units. Effective use of units would have made this an easy calculation. Explanations were few and candidates were clearly struggling with this aspect of energy.
- (iv) Many candidates were able to give one coherent reason but two distinct answers were rare.
- d. (i) As is often the case with this question, candidates state that “momentum is conserved” and fail to explain what this means. There was much confusion with energy conservation rules.
- (ii) Calculations of the final speed of the neutron were confused with little or no explanation of the equations. It was often not clear what mass values (if any) were being used in the solution.
- (iii) There were few clear solutions to this problem. Some candidates did not appreciate the meaning of fractional energy change and others were still travelling along the momentum route from an earlier part, scoring few, if any, marks.
- (iv) Candidates had evidently not considered the mechanical issues of moderation in their learning. There was little recognition that the change in fractional energy is $0.33n$ where n is the number of collisions. The most frequent answer was that the change is $0.33n$.
- (v) There was more clarity about the reasons for moderation but even so, answers were poorly expressed. Only a minority recognised that the probability of absorption is greatest at low neutron incident energy.

This question is in **two** parts. **Part 1** is about the production of energy in nuclear fission. **Part 2** is about collisions.

Part 1 Production of energy in nuclear fission

A possible fission reaction is

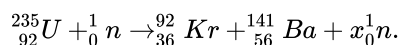

Part 2 Collisions

In an experiment, an air-rifle pellet is fired into a block of modelling clay that rests on a table.

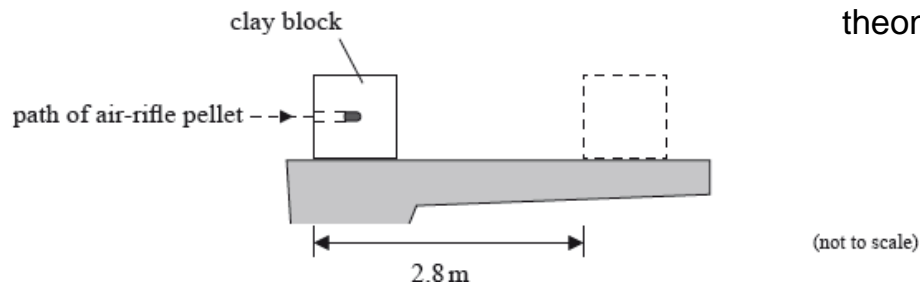

The air-rifle pellet remains inside the clay block after the impact.

As a result of the collision, the clay block slides along the table in a straight line and comes to rest. Further data relating to the experiment are given below.

Mass of air - rifle pellet	= 2.0 g
Mass of clay block	= 56 g
Velocity of impact of air - rifle pellet	= 140 m s^{-1}
Stopping distance of clay block	= 2.8 m

Part 1. State the value of x .

[6]

(ii) Show that the energy released when one uranium nucleus undergoes fission in the reaction in (a) is about $2.8 \times 10^{-11} \text{ J}$.

Mass of neutron	= 1.00867 u
Mass of U - 235 nucleus	= 234.99333 u
Mass of Kr - 92 nucleus	= 91.90645 u
Mass of Ba - 141 nucleus	= 140.88354 u

(iii) State how the energy of the neutrons produced in the reaction in (a) is likely to compare with the energy of the neutron that initiated the reaction.

Part 2. Outline the role of the moderator.

[2]

Part 3. A nuclear power plant that uses U-235 as fuel has a useful power output of 16 MW and an efficiency of 40%. Assuming that each fission of U-

[4]

235 gives rise to $2.8 \times 10^{-11} \text{ J}$ of energy, determine the mass of U-235 fuel used per day.

Part 4. State the principle of conservation of momentum.

[2]

Part 5. a. Show that the initial speed of the clay block after the air-rifle pellet strikes it is 4.8 m s^{-1} .

[6]

(ii) Calculate the average frictional force that the surface of the table exerts on the clay block whilst the clay block is moving.

Part 6. Discuss the energy transformations that occur in the clay block and the air-rifle pellet from the moment the air-rifle pellet strikes the block until

[3]

the clay block comes to rest.

Part 7. The clay block is dropped from rest from the edge of the table and falls vertically to the ground. The table is 0.85 m above the ground. Calculate

[2]

the speed with which the clay block strikes the ground.

Markscheme

Part 1. a.3;

$$(ii) \Delta m = 234.99333 - 91.90645 - 140.88354 - [2 \times 1.00867];$$

$$= 0.186 \text{ (u)};$$

$$\text{energy released} = 0.186 \times 931 = 173 \text{ (MeV)};$$

$$= 0.24 \text{ N};$$

Part 1. Thetic energy of pellet is transferred to kinetic energy of clay block;

and internal energy of pellet and clay block;

clay block loses kinetic energy as thermal energy/heat;

Part 2. d. $\sqrt{2gs}$;

$$= 4.1 \text{ m s}^{-1};$$

Allow $g = 10 \text{ m s}^{-2}$ answer 4.1 m s^{-2}

Award [2] for bald correct answer.

Examiners report

Part 1. a. A common incorrect answer was 2.

(ii) Candidates were often able to carry this calculation through to a correct conclusion. It was a “show that” and a high level of explanation was required by examiners and was – in many cases – demonstrated.

(iii) Responses here were mostly correct. However, the answer “It has a higher energy” was common. Candidates need to be reminded of the imprecision of such a statement. Is “It” the initiating neutron or the emitted neutron?

Part 2. a. Weaker candidates could not distinguish between the role of the moderator and that of the control rods.

Part 2. b. Many good calculations were seen but weaker candidates usually arrived at recognition that the required power from the reactor is 40 MW and could go no further.

Part 2. c. When the question is “State the principle of conservation of momentum.” an answer of “momentum is conserved” will attract no marks. The examiner needs to know what “conserved” means. Many omitted the statement that external forces do not act (or similar)

Part 2. d. Careful examination of solutions showed that about one-third of candidate forgot to add the mass of the pellet to the final total mass of the block.

(ii) This two-stage calculation attracted the same error as part (i) and many power of ten errors through a failure to note the units of mass in the question.

Part 2. e. Descriptions of the energy transformations were incomplete and poorly described. There was a general failure to recognise that the pellet transfers its kinetic energy into a number of distinct forms. Candidates are too quick to ascribe energy loss to “friction” without indicating the seat of this energy loss.

Part 2. f. Most candidates were able to complete this calculation or to get close to it. Some forgot to evaluate the square root having arrived at the speed squared.

This question is in **two** parts. **Part 1** is about Newton’s laws and momentum. **Part 2** is about the greenhouse effect.

Part 1 Newton’s laws and momentum

Part 2 The greenhouse effect
@TOPhysicsTutor

facebook.com/TheOnlinePhysicsTutor

- a. State the condition for the momentum of a system to be conserved. [1]
- b. A person standing on a frozen pond throws a ball. Air resistance and friction can be considered to be negligible. [5]
- (i) Outline how Newton's third law and the conservation of momentum apply as the ball is thrown.
- (ii) Explain, with reference to Newton's second law, why the horizontal momentum of the ball remains constant whilst the ball is in flight.
- c. The maximum useful power output of a locomotive engine is 0.75 M W. The maximum speed of the locomotive as it travels along a straight [2]
horizontal track is 44 m s⁻¹. Calculate the frictional force acting on the locomotive at this speed.
- d. The locomotive engine in (c) gives a truck X a sharp push such that X moves along a horizontal track and collides with a stationary truck Y. As a [4]
result of the collision the two trucks stick together and move off with speed v . The following data are available.
- Mass of truck X = 3.7×10^3 kg
 Mass of truck Y = 6.3×10^3 kg
 Speed of X just before collision = 4.0 m s⁻¹
- (i) Calculate v .
- (ii) Determine the kinetic energy lost as a result of the collision.
- e. The trucks X and Y come to rest after travelling a distance of 40 m along the horizontal track. Determine the average frictional force acting on X [3]
and Y.
- f. Nuclear fuels, unlike fossil fuels, produce no greenhouse gases. [5]
- (i) Identify **two** greenhouse gases.
- (ii) Discuss, with reference to the mechanism of infrared absorption, why the temperature of the Earth's surface would be lower if there were no greenhouse gases present in the atmosphere.
- g. Outline how an increase in the amount of greenhouse gases in the atmosphere of Earth could lead to an increase in the rate at which glaciers [3]
melt and thereby a reduction of the albedo of the Earth's surface.

Markscheme

- a. the net (external) force acting on the system is zero / no force acting on system / system is isolated;
- b. (i) no external force/system is isolated so change in momentum is zero; { *(do not accept momentum is conserved/constant)*
force on ball must be equal and opposite to force on the person;
so ball and person/Earth/pond move in opposite directions;
- (ii) Newton's second law states that the rate of change of momentum is equal/proportional/directly proportional to the force acting;
the horizontal force acting on the ball is zero therefore the momentum must be constant/the rate of change of momentum is zero;
- or**
- Newton's second law can be expressed as the force acting is equal to the product of mass and acceleration;
the horizontal force acting on the ball is zero therefore the acceleration is zero so velocity is constant (and therefore momentum is constant);
- c. $F = \frac{P}{v}$ **or** $\frac{0.75 \times 10^6}{44}$;
17kN;

d. (i) $3.7 \times 4.0 = 10 \times v$;

$$v = 1.5 \text{ms}^{-1};$$

$$\begin{aligned} \text{(ii) KE lost} &= \frac{1}{2} [3.7 \times 10^3 \times 4.0^2] - \frac{1}{2} [10 \times 10^3 \times 1.5^2]; \\ &= 18 \text{kJ}; \end{aligned}$$

e. initial KE = $\left(\frac{1}{2} [10 \times 10^3 \times 1.5^2] \right) = 11250 \text{J}$;

$$\text{friction} = \frac{11250}{40};$$

$$= 280 \text{N};$$

or

use of kinematic equation to give $a = 0.274 \text{ms}^{-1}$;

use of $F (=ma) = 10 \times 10^3 a$;

$$270/280 \text{N};$$

f. (i) methane/ CH_4 , water vapour/ H_2O , carbon dioxide/ CO_2 , nitrous oxide/ N_2O ;

Award [1] for any two of the above.

(ii) *mechanism:*

mention of resonance;

natural frequency of (resonating) greenhouse gas molecules is same as that of infrared radiation from Earth;

or

mention of energy level differences;

differences between energy levels of greenhouse gas molecules matches energy of infrared radiation from Earth;

explanation:

less infrared trapped if absorption is reduced;

so more infrared is transmitted through atmosphere;

or

more infrared is trapped if absorption is increased;

so more infrared is re-radiated back to Earth;

Allow only one variant for each alternative.

g. more greenhouse gas therefore more infrared radiated back to Earth;

leading to an increase in temperature of glaciers/surface;

less glacier area so less reflection from glacier surface / *OWTTE*;

albedo defined as $\frac{\text{amount of radiation reflected}}{\text{amount of radiation absorbed}}$ therefore albedo reduced;

Examiners report

a. [N/A]

b. [N/A]

c. [N/A]

d. [N/A]

e. [N/A]

f. [N/A]

g. [N/A]

Part 1 Motion of a ship

Some cargo ships use kites working together with the ship's engines to move the vessel.

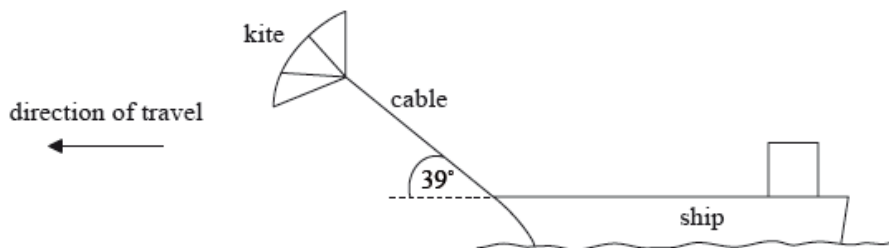

The tension in the cable that connects the kite to the ship is 250 kN. The kite is pulling the ship at an angle of 39° to the horizontal. The ship travels at a steady speed of 8.5 m s^{-1} when the ship's engines operate with a power output of 2.7 MW.

The ship's engines are switched off and the ship comes to rest from a speed of 7 m s^{-1} in a time of 650 s.

Part 2 Melting ice

A container of negligible mass, isolated from its surroundings, contains 0.150 kg of ice at a temperature of -18.7°C . An electric heater supplies energy at a rate of 125 W.

- a. Outline the meaning of work. [2]
- b.i. Calculate the work done on the ship by the kite when the ship travels a distance of 1.0 km. [2]
- b.ii. Show that, when the ship is travelling at a speed of 8.5 m s^{-1} , the kite provides about 40% of the total power required by the ship. [4]
- c. The kite is taken down and no longer produces a force on the ship. The resistive force F that opposes the motion of the ship is related to the speed v of the ship by [3]

$$F = kv^2$$

where k is a constant.

Show that, if the power output of the engines remains at 2.7 MW, the speed of the ship will decrease to about 7 m s^{-1} . Assume that k is independent of whether the kite is in use or not.

- d.i. Estimate the distance that the ship takes to stop. Assume that the acceleration is uniform. [2]
- d.ii. It is unlikely that the acceleration of the ship will be uniform given that the resistive force acting on the ship depends on the speed of the ship. [2]

Using the axes, sketch a graph to show how the speed v varies with time t after the ship's engines are switched off.

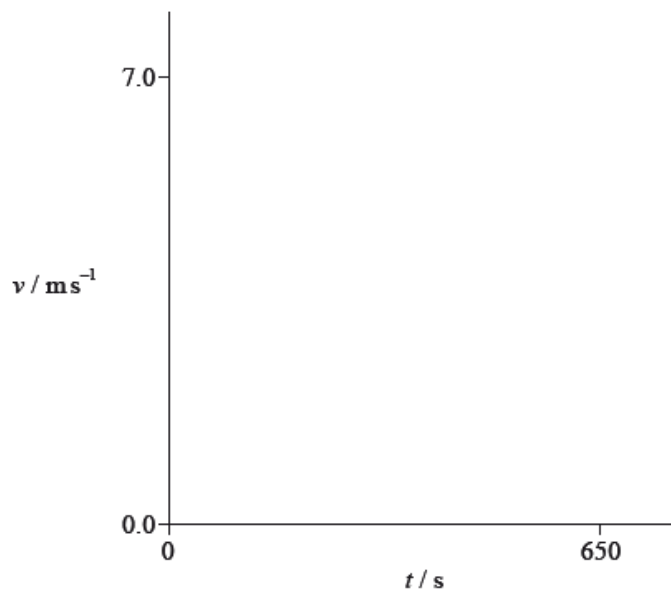

e. Describe, with reference to molecular behaviour, the process of melting ice. [2]

f.i. After a time interval of 45.0 s all of the ice has reached a temperature of 0 °C without any melting. Calculate the specific heat capacity of ice. [2]

f.ii. The following data are available. [3]

$$\text{Specific heat capacity of water} = 4200 \text{ J kg}^{-1}\text{K}^{-1}$$

$$\text{Specific latent heat of fusion of ice} = 3.30 \times 10^5 \text{ J kg}^{-1}$$

Determine the final temperature of the water when the heater supplies energy for a further 600 s.

g. The whole of the experiment in (f)(i) and (f)(ii) is repeated with a container of negligible mass that is not isolated from the surroundings. The temperature of the surroundings is 18 °C. Comment on the final temperature of the water in (f)(ii). [3]

Markscheme

a. work done = force \times distance moved;

(distance moved) in direction of force;

or

energy transferred;

from one location to another;

or

work done = $Fs \cos \theta$;

with each symbol defined;

b.i. horizontal force = $250\,000 \times \cos 39^\circ (= 1.94 \times 10^5 \text{ N})$;

work done = $1.9 \times 10^8 \text{ J}$;

b.ii. power provided by kite = $(1.94 \times 10^5 \times 8.5 =) 1.7 \times 10^6 \text{ W}$;

total power = $(2.7 + 1.7) \times 10^6 \text{ W} (= 4.4 \times 10^6 \text{ W})$;

fraction provided by kite = $\frac{1.7}{2.7+1.7}$;

38% **or** 0.38; (must see answer to 2+ sig figs as answer is given)

Allow answers in the range of 37 to 39% due to early rounding.

or

Award [3 max] for a reverse argument such as:

if 2.7 MW is 60%;

then kite power is $\frac{2}{3} \times 2.7 \text{ MW} = 1.8 \text{ MW}$;

shows that kite power is actually 1.7 MW; (QED)

c. $P = (kv^2) \times v = kv^3$;

$$\frac{v_1}{v_2} = \left(\sqrt[3]{\left(\frac{P_1}{P_2}\right)} \right) = \sqrt[3]{\left(\frac{7.7}{4.4}\right)}$$

final speed of ship = 7.2 m s^{-1} ; (at least 2 sig figs required).

Approximate answer given, marks are for working only.

d.i. correct substitution of 7 or 7.2 into appropriate kinematic equation;

an answer in the range of 2200 to 2400 m;

d.ii starts at $7.0/7.2 \text{ m s}^{-1}$; (allow ECF from (d)(i))

correct shape;

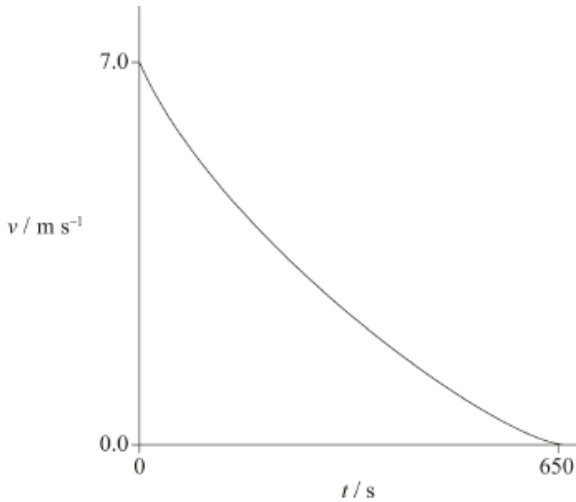

e. in ice, molecules vibrate about a fixed point;

as their total energy increases, the molecules (partly) overcome the attractive force between them;

in liquid water the molecules are able to migrate/change position;

f.i. ($Q =$) $45.0 \times 125 (= 5625 \text{ J})$;

$$c = \left(\frac{Q}{m\Delta\theta} \right) = 2.01 \times 10^3 \text{ J kg}^{-1}\text{K}^{-1}$$

f.ii. energy available = $125 \times 600 (= 75000 \text{ J})$;

energy available to warm the water = $75000 - [0.15 \times 3.3 \times 10^5] (= 25500 \text{ J})$;

$$\text{temperature} = \left(\frac{25500}{0.15 \times 4200} \right) = 40.5^\circ \text{C}$$

g. ice/water spends more time below 18°C ;

so net energy transfer is in to the system;

so final water temperature is higher;

or

ice/water spends less time below 18 °C;
so net energy transfer is out of the system;
so final water temperature is lower;

Examiners report

- a. [N/A]
b.i. [N/A]
b.ii. This is a “show that” question which means that the candidate is obliged to show their line of reasoning. Very few SL candidates did this.
- c. This was easy using proportionality, but most candidates at SL attempted to calculate k unnecessarily. Even so there were many correct answers.
- d.i. [N/A]
d.ii. [N/A]
- e. A minority of candidates knew that molecules made a transition from being localised to being free to migrate, but had difficulty expressing their answers coherently. Candidates are so used to commenting on the energy transformations when ice melts, that many completely misread the question.
- f.i. Many good answers, although those that did not get the correct answers presented their working in such a way that part marks (ECF) were not able to be given.
- f.ii. Many good answers, although those that did not get the correct answers presented their working in such a way that part marks (ECF) were not able to be given.
- g. The significance of the temperature of the surroundings was ignored by nearly all candidates, but most were able to obtain 2 marks for suggesting that thermal energy would be lost to the surroundings causing a lower final temperature.
-

Part 2 Electric motor

An electric motor is used to raise a load.

- a. Whilst being raised, the load accelerates uniformly upwards. The weight of the cable is negligible compared to the weight of the load. [6]
- (i) Draw a labelled free-body force diagram of the forces acting on the accelerating load. The dot below represents the load.



(ii) The load has a mass of 350 kg and it takes 6.5 s to raise it from rest through a height of 8.0 m.

Determine the tension in the cable as the load is being raised.

b. The electric motor can be adjusted such that, after an initial acceleration, the load moves at constant speed. The motor is connected to a 450 V [4]

supply and with the load moving at constant speed, it takes the motor 15 s to raise the load through 7.0 m.

(i) Calculate the power delivered to the load by the motor.

(ii) The current in the motor is 30 A. Estimate the efficiency of the motor.

Markscheme

- a. (i) upward arrow labelled T /tension/force in cable and downward arrow labelled W/mg /weight/gravity force; { *both needed* }

tension arrow length > weight length;

$$(ii) a = \frac{2s}{t^2};$$

$$a = \left(\frac{2 \times 8.0}{6.5^2} \right) = 0.38 \text{ (ms}^{-2}\text{)};$$

$$T = ma + mg \text{ or } T = 350(0.38 + 9.8);$$

3.6 kN;

Allow $g = 10 \text{ N kg}^{-1}$ (same answer to 2 sf).

- b. (i) change in gpe = $350 \times 9.81 \times 7.0 (= 24 \text{ kJ})$;

$$\text{power} \left(= \frac{24 \times 10^3}{15} \right) = 1.6 \text{ kW};$$

Allow $g = 10 \text{ N kg}^{-1}$.

- (ii) power input to motor = 13.5 (kW);

$$\text{efficiency} = \left(\frac{1.6}{13.5} \right) = 0.12 \text{ or } 12\%;$$

Examiners report

a. [N/A]

b. [N/A]

A girl on a sledge is moving down a snow slope at a uniform speed.

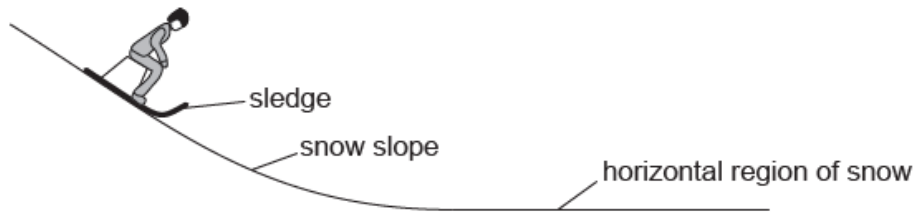

The sledge, without the girl on it, now travels up a snow slope that makes an angle of 6.5° to the horizontal. At the start of the slope, the speed of the sledge is 4.2 m s^{-1} . The coefficient of dynamic friction of the sledge on the snow is 0.11.

- a. Draw the free-body diagram for the sledge at the position shown on the snow slope. [2]
- b. After leaving the snow slope, the girl on the sledge moves over a horizontal region of snow. Explain, with reference to the physical origin of the forces, why the vertical forces on the girl must be in equilibrium as she moves over the horizontal region. [3]
- c. When the sledge is moving on the horizontal region of the snow, the girl jumps off the sledge. The girl has no horizontal velocity after the jump. [2]
The velocity of the sledge immediately after the girl jumps off is 4.2 m s^{-1} . The mass of the girl is 55 kg and the mass of the sledge is 5.5 kg.
Calculate the speed of the sledge immediately before the girl jumps from it.
- d. The girl chooses to jump so that she lands on loosely-packed snow rather than frozen ice. Outline why she chooses to land on the snow. [3]
- e.i. Show that the acceleration of the sledge is about -2 m s^{-2} . [3]

e.ii. Calculate the distance along the slope at which the sledge stops moving. Assume that the coefficient of dynamic friction is constant. [2]

f. The coefficient of static friction between the sledge and the snow is 0.14. Outline, with a calculation, the subsequent motion of the sledge. [2]

Markscheme

a. arrow vertically downwards labelled weight «of sledge and/or girl»/W/mg/gravitational force/ F_g / $F_{\text{gravitational}}$ **AND** arrow perpendicular to the snow

slope labelled reaction force/R/normal contact force/N/ F_N

friction force/ F / f acting up slope «perpendicular to reaction force»

Do not allow G/g/“gravity”.

Do not award MP1 if a “driving force” is included.

Allow components of weight if correctly labelled.

Ignore point of application or shape of object.

Ignore “air resistance”.

Ignore any reference to “push of feet on sledge”.

Do not award MP2 for forces on sledge on horizontal ground

The arrows should contact the object

b. gravitational force/weight from the Earth «downwards»

reaction force from the sledge/snow/ground «upwards»

no vertical acceleration/remains in contact with the ground/does not move vertically as there is no resultant vertical force

Allow naming of forces as in (a)

Allow vertical forces are balanced/equal in magnitude/cancel out

c. mention of conservation of momentum

OR

$$5.5 \times 4.2 = (55 + 5.5) \llcorner v \llcorner$$

$$0.38 \llcorner \text{m s}^{-1} \llcorner$$

Allow $p=p'$ or other algebraically equivalent statement

Award [0] for answers based on energy

d. same change in momentum/impulse

the time taken «to stop» would be greater «with the snow»

$$F = \frac{\Delta p}{\Delta t} \text{ therefore } F \text{ is smaller «with the snow»}$$

OR

force is proportional to rate of change of momentum therefore F is smaller «with the snow»

Allow reverse argument for ice

e.i. «friction force down slope» = $\mu mg \cos(6.5)$ = «5.9 N»

«component of weight down slope» = $mg \sin(6.5)$ «= 6.1 N»

«so $a = \frac{F}{m}$ » acceleration = $\frac{12}{5.5} = 2.2$ «m s⁻²»

Ignore negative signs

Allow use of $g = 10 \text{ m s}^{-2}$

e.ii.correct use of kinematics equation

distance = 4.4 **or** 4.0 «m»

Alternative 2

KE lost=work done against friction + GPE

distance = 4.4 **or** 4.0 «m»

Allow ECF from (e)(i)

Allow **[1 max]** for GPE missing leading to 8.2 «m»

f. calculates a maximum value for the frictional force = « μR » 7.5 «N»

sledge will not move as the maximum static friction force is greater than the component of weight down the slope

Allow correct conclusion from incorrect MP1

Allow $7.5 > 6.1$ so will not move

Examiners report

- a. [N/A]
- b. [N/A]
- c. [N/A]
- d. [N/A]
- e.i. [N/A]
- e.ii. [N/A]
- f. [N/A]

An elastic climbing rope is tested by fixing one end of the rope to the top of a crane. The other end of the rope is connected to a block which is initially at position A. The block is released from rest. The mass of the rope is negligible.

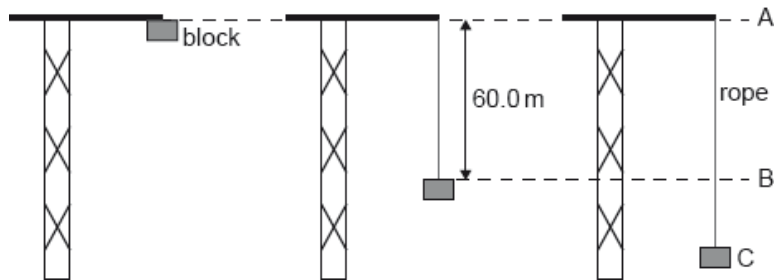

The unextended length of the rope is 60.0 m. From position A to position B, the block falls freely.

At position C the speed of the block reaches zero. The time taken for the block to fall between B and C is 0.759 s. The mass of the block is 80.0 kg.

For the rope and block, describe the energy changes that take place

- a. At position B the rope starts to extend. Calculate the speed of the block at position B.

b.i. Determine the magnitude of the average resultant force acting on the block between B and C. [2]

b.ii. Sketch on the diagram the average resultant force acting on the block between B and C. The arrow on the diagram represents the weight of the block. [2]

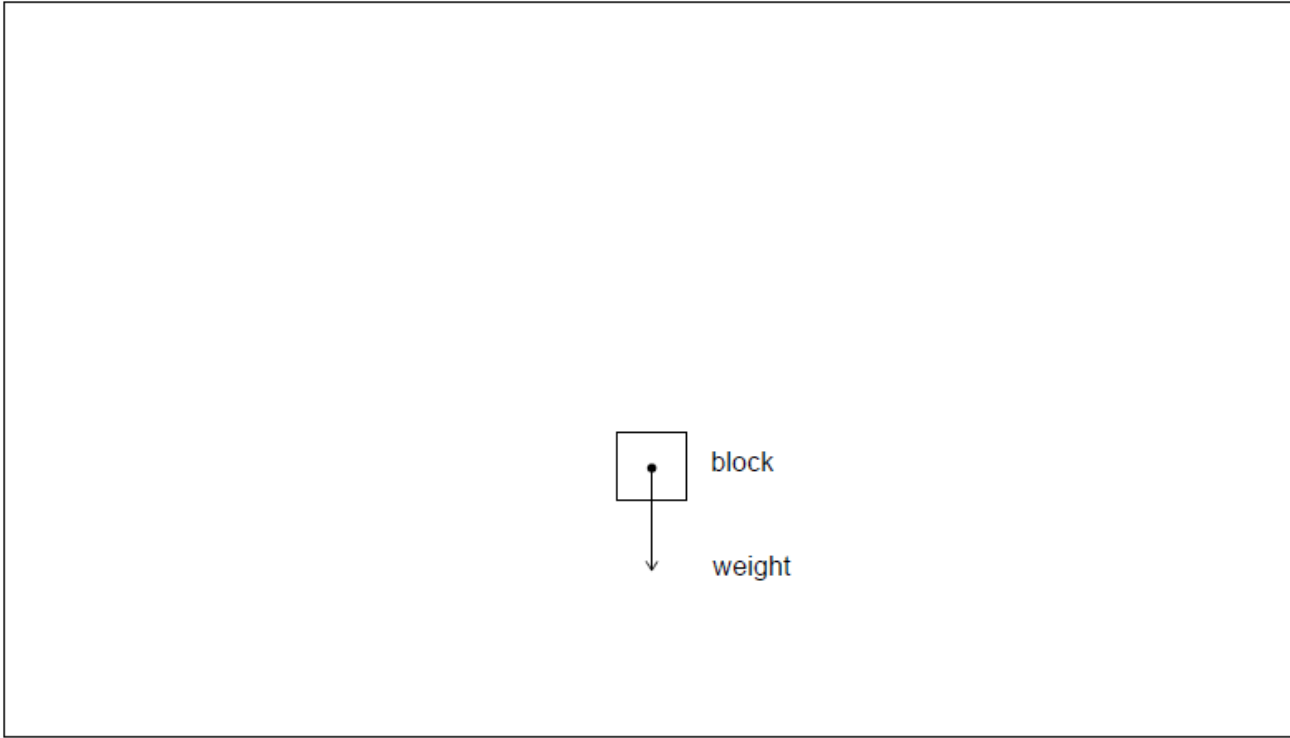

b.iii. Calculate the magnitude of the average force exerted by the rope on the block between B and C. [2]

c.i. between A and B. [1]

c.ii. between B and C. [1]

d. The length reached by the rope at C is 77.4 m. Suggest how energy considerations could be used to determine the elastic constant of the rope. [2]

Markscheme

a. use of conservation of energy

OR

$$v^2 = u^2 + 2as$$

$$v = \sqrt{2 \times 60.0 \times 9.81} = 34.3 \text{ «ms}^{-1}\text{»}$$

[2 marks]

b.i. use of impulse $F_{\text{ave}} \times \Delta t = \Delta p$

OR

use of $F = ma$ with average acceleration

OR

$$F = \frac{80.0 \times 34.3}{0.759}$$

3620 «N»

Allow ECF from (a).

[2 marks]

b.ii.upwards

clearly longer than weight

For second marking point allow ECF from (b)(i) providing line is upwards.

[2 marks]

b.iii $3620 + 80.0 \times 9.81$

4400 «N»

Allow ECF from (b)(i).

[2 marks]

c.i. (loss in) gravitational potential energy (of block) into kinetic energy (of block)

Must see names of energy (gravitational potential energy and kinetic energy) – Allow for reasonable variations of terminology (eg energy of motion for KE).

[1 mark]

c.ii. (loss in) gravitational potential and kinetic energy of block into elastic potential energy of rope

See note for 1(c)(i) for naming convention.

Must see either the block or the rope (or both) mentioned in connection with the appropriate energies.

[1 mark]

d. k can be determined using $EPE = \frac{1}{2}kx^2$

correct statement or equation showing

GPE at A = EPE at C

OR

(GPE + KE) at B = EPE at C

Candidate must clearly indicate the energy associated with either position A or B for MP2.

[2 marks]

Examiners report

a. [N/A]

b.i. [N/A]

b.ii. [N/A]

b.iii. [N/A]

[N/A]

- c.ii. [N/A]
 d. [N/A]

This question is in **two** parts. **Part 1** is about kinematics and mechanics. **Part 2** is about electric potential difference and electric circuits.

Part 1 Kinematics and mechanics

- a. Define *linear momentum*. [1]
- b. State, in terms of momentum, Newton's second law of motion. [1]
- c. Show, using your answer to (b), how the impulse of a force F is related to the change in momentum Δp that it produces. [1]
- c. Show, using your answer to (b), how the impulse of a force F is related to the change in momentum Δp that it produces. [1]
- d. A railway truck on a level, straight track is initially at rest. The truck is given a quick, horizontal push by an engine so that it now rolls along the track. [12]

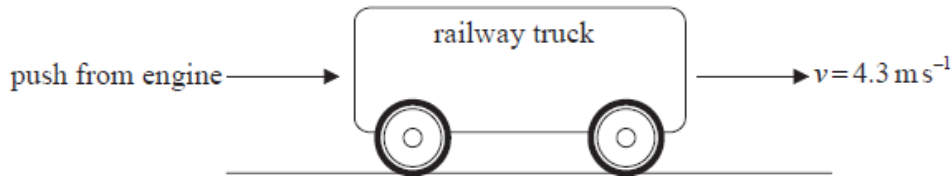

The engine is in contact with the truck for a time $T = 0.54$ s and the initial speed of the truck after the push is 4.3 ms^{-1} . The mass of the truck is 2.2×10^3 kg.

Due to the push, a force of magnitude F is exerted by the engine on the truck. The sketch shows how F varies with contact time t .

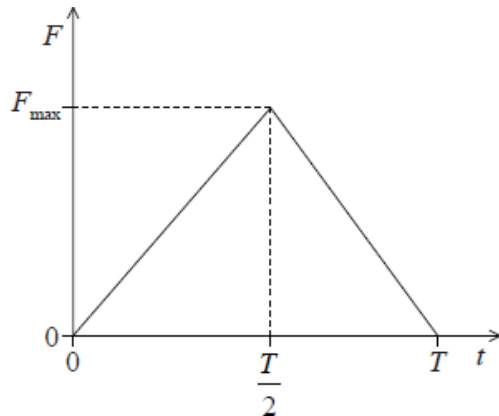

- (i) Determine the magnitude of the maximum force F_{max} exerted by the engine on the truck.
- (ii) After contact with the engine ($t = 0.54$ s) the truck moves a distance 15 m along the track. After travelling this distance the speed of the truck is 2.8 ms^{-1} . Assuming a uniform acceleration, calculate the time it takes the truck to travel 15 m.
- (iii) Calculate the average rate at which the kinetic energy of the truck is dissipated as it moves along the track.
- (iv) When the speed of the truck is 2.8 ms^{-1} it collides with a stationary truck of mass 3.0×10^3 kg. The two trucks move off together with a speed V . Show that the speed $V = 1.2 \text{ ms}^{-1}$.
- (v) Outline the energy transformations that take place during the collision of the two trucks.

Markscheme

- a. mass \times velocity; (allow mv with symbols defined)

b. the rate of change of momentum of a body is equal to/directly proportional to the force acting on the body;

Accept $F = \frac{\Delta p}{\Delta t}$ only if all symbols are defined.

c. $\left(F = \frac{\Delta p}{\Delta t}\right)$

therefore impulse $F\Delta t = \Delta p$; (accept t for Δt)

c. $\left(F = \frac{\Delta p}{\Delta t}\right)$

therefore impulse $F\Delta t = \Delta p$; (accept t for Δt)

d. (i) (impulse=) change in momentum= $2.2 \times 10^3 \times 4.3 (=9.46 \times 10^3 \text{Ns})$;

impulse=area under graph= $\frac{1}{2}F_{\text{max}}\Delta t$;

$$\frac{1}{2}F_{\text{max}} \times 0.54 = 9.46 \times 10^3;$$

$$F_{\text{max}} = 35 \text{k(N)} \text{ or } 3.5 \times 10^4 \text{ (N)};$$

(ii) (magnitude of) acceleration= $\left(\frac{u^2 - v^2}{2s} = \frac{4.3^2 - 2.8^2}{30} =\right) 0.355 \text{ms}^{-2}$;

$$\text{time} = \left(\frac{u - v}{a} = \frac{1.5}{0.355} =\right) 4.2 \text{s};$$

Award **[1 max]** if an additional 0.54 s is added to answer.

(iii) $\Delta KE = \left(\frac{1}{2} \times 2.2 \times 10^3 [4.3^2 - 2.8^2] =\right) 1.17 \times 10^4 \text{J}$;

$$\text{rate of change of } \Delta KE = \frac{1.17 \times 10^4}{4.2} = 2.8 \text{kW}$$

(mark is for division by 4.2 and correct calculation)

(iv) statement of momentum conservation:

e.g. momentum of the truck before collision=momentum of both trucks after collision;

(allow clear symbolism instead of words)

$$2.2 \times 10^3 \times 2.8 = 5.2 \times 10^3 V \text{ or } V = \frac{2.2}{5.2} \times 2.8;$$

to give $V = 1.2 \text{ms}^{-1}$

(v) the first truck loses kinetic energy that is transferred to internal energy in the links between the trucks (and as sound);

and to kinetic energy of the stationary truck;

Award **[0]** for "lost as heat, light and sound", or "in air resistance".

Examiners report

a. Linear momentum was defined accurately. Only a handful used speed rather than velocity in the definition.

b. Newton's second law of motion appeared to be well understood but some failed to quote it in the context of momentum and gave the simpler statement in terms of $F=ma$.

c. Many were able to show that impulse is equal to the change in momentum.

c. Many were able to show that impulse is equal to the change in momentum.

d. (i) This was another question where candidates let themselves down very badly with their quality of explanation and presentation. Although many obtained the correct answer it was often not clear that they had fully appreciated the assumptions they were making. Examiners (for full credit) were looking for explanations typically in terms of the area under the $F-t$ graph – it was rare to see this – with a full consideration of the evaluation of the isosceles triangle. Many candidates will have scored only one mark for an evaluation of the momentum change (usually by inference rather than by direct candidate statement) and one mark for the answer.

(ii) This straightforward application of the kinematic equations was often well done, but some candidates failed to read the question carefully and could not identify the correct values for the speed of the truck.

(iii) A common error was to evaluate $(4.8-2.3)^2$ rather than the correct $(4.2^2-2.8^2)$ in the route towards the change in kinetic energy. However, whether evaluating the correct change in kinetic energy or not, most were able to divide a value for the change by the time calculated in (ii) to determine an average rate of energy dissipation.

(iv) Candidates were required to indicate the basis for the calculation (conservation of momentum) and to identify the algebraic or numerical method they were using. Although many gained full marks, once again candidates did not make it easy for examiners to establish the basis for the method. Clear statements of momentum conservation were rare and examiners were frequently expected to infer the method from an undefined set of symbols sometimes unrelated to this particular problem.

(v) Most candidates gained one mark from this question by outlining the transfer in kinetic energy from first to second truck. Few recognized the role of the trucks' coupling mechanism preferring to emphasize the relatively minor and generalized roles of heat and sound dissipation in the collision. This is a frequent response in energy transfer questions such as this; candidates should consider specific examples in the question rather than making recourse to more general issues of energy transfer.

The diagram below shows part of a downhill ski course which starts at point A, 50 m above level ground. Point B is 20 m above level ground.

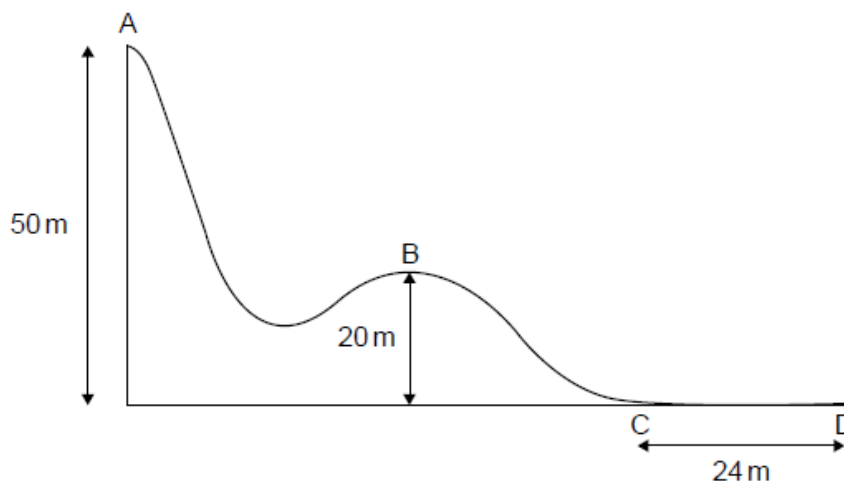

A skier of mass 65 kg starts from rest at point A and during the ski course some of the gravitational potential energy transferred to kinetic energy.

At the side of the course flexible safety nets are used. Another skier of mass 76 kg falls normally into the safety net with speed 9.6 m s^{-1} .

a.i. From A to B, 24 % of the gravitational potential energy transferred to kinetic energy. Show that the velocity at B is 12 m s^{-1} . [2]

a.ii. Some of the gravitational potential energy transferred into internal energy of the skis, slightly increasing their temperature. Distinguish between internal energy and temperature. [2]

b.i. The dot on the following diagram represents the skier as she passes point B. [2]

Draw and label the vertical forces acting on the skier.

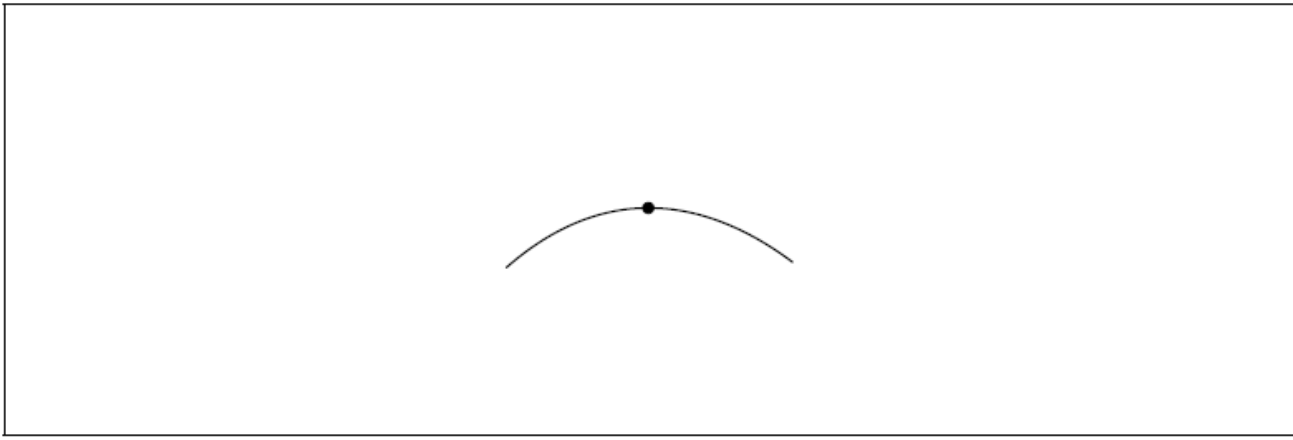

b.ii. The hill at point B has a circular shape with a radius of 20 m. Determine whether the skier will lose contact with the ground at point B. [3]

c. The skier reaches point C with a speed of 8.2 m s^{-1} . She stops after a distance of 24 m at point D. [3]

Determine the coefficient of dynamic friction between the base of the skis and the snow. Assume that the frictional force is constant and that air resistance can be neglected.

d.i. Calculate the impulse required from the net to stop the skier and state an appropriate unit for your answer. [2]

d.ii. Explain, with reference to change in momentum, why a flexible safety net is less likely to harm the skier than a rigid barrier. [2]

Markscheme

a.i. $\frac{1}{2} v^2 = 0.24 gh$

$v = 11.9 \text{ «m s}^{-1}\text{»}$

Award GPE lost = $65 \times 9.81 \times 30 = \text{«19130 J»}$

Must see the 11.9 value for MP2, not simply 12.

Allow $g = 9.8 \text{ ms}^{-2}$.

a.ii. internal energy is the total KE «and PE» of the molecules/particles/atoms in an object

temperature is a measure of the average KE of the molecules/particles/atoms

Award [1 max] if there is no mention of molecules/particles/atoms.

b.i. arrow vertically downwards from dot labelled weight/W/mg/gravitational force/ $F_g/F_{\text{gravitational}}$ **AND** arrow vertically upwards from dot labelled

reaction force/R/normal contact force/ N/F_N

$W > R$

Do not allow gravity.

Do not award MP1 if additional 'centripetal' force arrow is added.

Arrows must connect to dot.

Ignore any horizontal arrow labelled friction.

Judge by eye for MP2. Arrows do not have to be correctly labelled or connect to dot for MP2.

b.ii. **ALTERNATIVE 1**

recognition that centripetal force is required / $\frac{mv^2}{r}$ seen

$$= 468 \text{ «N»}$$

W/640 N (weight) is larger than the centripetal force required, so the skier does not lose contact with the ground

ALTERNATIVE 2

recognition that centripetal acceleration is required / $\frac{v^2}{r}$ seen

$$a = 7.2 \text{ «ms}^{-2}\text{»}$$

g is larger than the centripetal acceleration required, so the skier does not lose contact with the ground

ALTERNATIVE 3

recognition that to lose contact with the ground centripetal force \geq weight

$$\text{calculation that } v \geq 14 \text{ «ms}^{-1}\text{»}$$

comment that 12 «ms⁻¹» is less than 14 «ms⁻¹» so the skier does not lose contact with the ground

ALTERNATIVE 4

recognition that centripetal force is required / $\frac{mv^2}{r}$ seen

$$\text{calculation that reaction force} = 172 \text{ «N»}$$

reaction force > 0 so the skier does not lose contact with the ground

Do not award a mark for the bald statement that the skier does not lose contact with the ground.

c. ALTERNATIVE 1

$$0 = 8.2^2 + 2 \times a \times 24 \text{ therefore } a = \text{«-»}1.40 \text{ «m s}^{-2}\text{»}$$

$$\text{friction force} = ma = 65 \times 1.4 = 91 \text{ «N»}$$

$$\text{coefficient of friction} = \frac{91}{65 \times 9.81} = 0.14$$

ALTERNATIVE 2

$$KE = \frac{1}{2}mv^2 = 0.5 \times 65 \times 8.2^2 = 2185 \text{ «J»}$$

$$\text{friction force} = KE/\text{distance} = 2185/24 = 91 \text{ «N»}$$

$$\text{coefficient of friction} = \frac{91}{65 \times 9.81} = 0.14$$

Allow ECF from MP1.

$$\text{d.i. «}76 \times 9.6\text{»} = 730$$

$$\text{Ns OR kg ms}^{-1}$$

d.ii safety net extends stopping time

$$F = \frac{\Delta p}{\Delta t} \text{ therefore } F \text{ is smaller «with safety net»}$$

OR

force is proportional to rate of change of momentum therefore F is smaller «with safety net»

Examiners report

- a.i. [N/A]
 a.ii. [N/A]
 b.i. [N/A]
 b.ii. [N/A]
 c. [N/A]
 d.i. [N/A]
 d.ii. [N/A]

This question is in **two** parts. **Part 1** is about momentum change. **Part 2** is about an oscillating water column (OWC) energy converter.

Part 1 Momentum change

a. State the law of conservation of linear momentum. [2]

b. Gravel falls vertically onto a moving horizontal conveyor belt. [7]

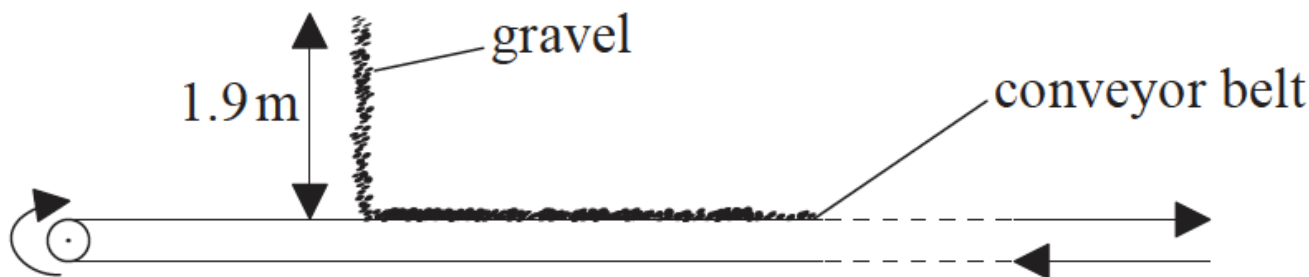

(i) The gravel falls at a constant rate of 13 kg s^{-1} through a height of 1.9 m . Show that the vertical speed of the gravel as it lands on the conveyor belt is about 6 m s^{-1} .

(ii) The gravel lands on the conveyor belt without rebounding. Calculate the rate of change of the vertical momentum of the gravel.

(iii) Gravel first reaches the belt at $t = 0.0 \text{ s}$ and continues to fall. Determine the total vertical force that the gravel exerts on the conveyor belt at $t = 5.0 \text{ s}$.

c. The conveyor belt moves with a constant horizontal speed of 1.5 m s^{-1} . As the gravel lands on the belt, it has no horizontal speed. [4]

(i) Calculate the rate of change of the kinetic energy of the gravel due to its change in horizontal speed.

(ii) Determine the power required to move the conveyor belt at constant speed.

(iii) Outline why the answers to (c)(i) and (ii) are different.

Markscheme

a. if no external forces act / isolated system;

momentum is constant / (total) momentum before=(total) momentum after;

b. (i) use of $v = \sqrt{2gh}$;

6.11 ms^{-1} ; (must show calculation to better than 1 sf)

(ii) rate of change of vertical momentum = 13×6.11 ;
79N; (accept answers in the range of 78N to 80N)

(iii) mass accrued = $5.0 \times 13 = 65\text{kg}$;
weight of this mass (= 65×9.8) = 637N; (650 from $g = 10\text{ms}^{-2}$)
total force ($637 + 79$) = 716N; } (allow ECF from (b)(ii) and from incorrect weight)

c. (i) 14.6Js^{-1} ;

(ii) horizontal momentum gain per second = 13×1.5 (= 19.5kgms^{-1});
power required = 29.3W;

(iii) additional energy/power required to accelerate gravel (through friction at the surface of the belt) / the gravel has to slip to gain horizontal speed / OWTTE;

Examiners report

- a. [N/A]
b. [N/A]
c. [N/A]

This question is about motion in a magnetic field.

An electron, that has been accelerated from rest by a potential difference of 250 V, enters a region of magnetic field of strength 0.12 T that is directed into the plane of the page.

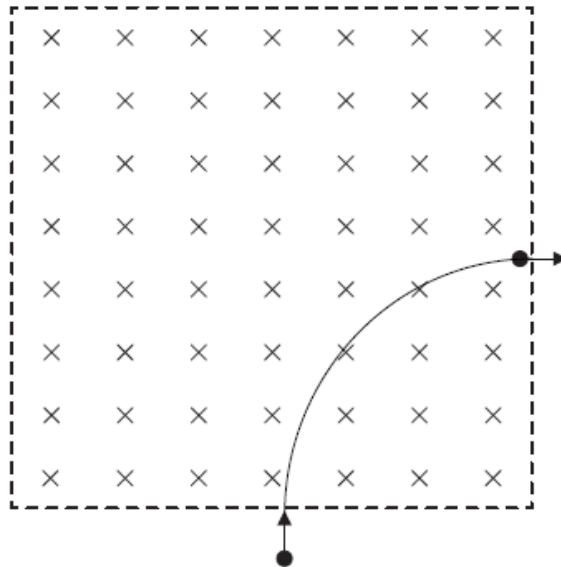

- a. The electron's path while in the region of magnetic field is a quarter circle. Show that the [4]
(i) speed of the electron after acceleration is $9.4 \times 10^6\text{ms}^{-1}$.
(ii) radius of the path is $4.5 \times 10^{-4}\text{m}$.
- b. The diagram below shows the momentum of the electron as it enters and leaves the region of magnetic field. The magnitude of the initial [3]
momentum and of the final momentum is $8.6 \times 10^{-24}\text{Ns}$.

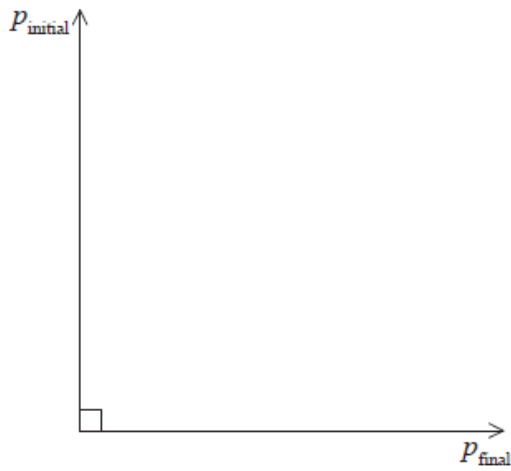

- (i) On the diagram above, draw an arrow to indicate the vector representing the change in the momentum of the electron.
- (ii) Show that the magnitude of the change in the momentum of the electron is $1.2 \times 10^{-23} \text{Ns}$.
- (iii) The time the electron spends in the region of magnetic field is $7.5 \times 10^{-11} \text{s}$. Estimate the magnitude of the average force on the electron.

Markscheme

a. (i) $v = \sqrt{\frac{2eV}{m}}$;
 $v = \sqrt{\frac{2 \times 1.6 \times 10^{-19} \times 250}{9.1 \times 10^{-31}}}$;
 $= 9.4 \times 10^6 \text{ms}^{-1}$

(ii) $evB = m \frac{v^2}{r}$;
 $r = \frac{9.1 \times 10^{-31} \times 9.4 \times 10^6}{1.6 \times 10^{-19} \times 0.12}$;
 $= 4.5 \times 10^{-4} \text{m}$

- b. (i) vector as shown;

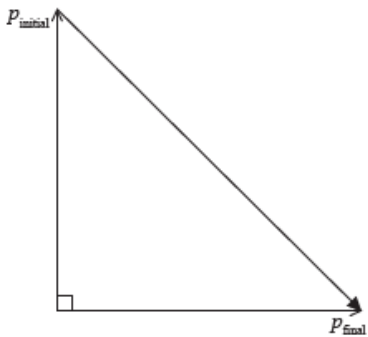

(ii) $\Delta p = \sqrt{[8.6 \times 10^{-24}]^2 + [8.6 \times 10^{-24}]^2}$;
 $= 1.2 \times 10^{-23} \text{Ns}$

(iii) $F \left(= \frac{\Delta p}{\Delta t} = \frac{1.2 \times 10^{-23}}{7.5 \times 10^{-11}} \right) = 1.6 \times 10^{-13} \text{N}$;

Examiners report

- a. [N/A]
b. [N/A]

This question is about circular motion.

A ball of mass 0.25 kg is attached to a string and is made to rotate with constant speed v along a horizontal circle of radius $r = 0.33\text{m}$. The string is attached to the ceiling and makes an angle of 30° with the vertical.

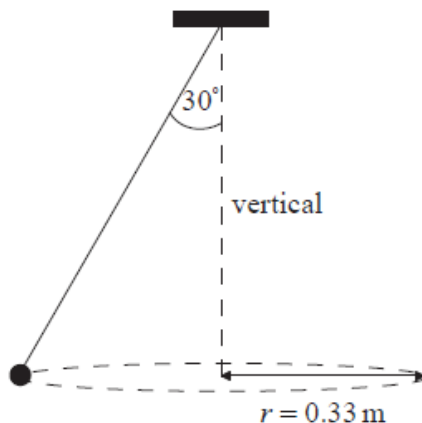

a. (i) On the diagram above, draw and label arrows to represent the forces on the ball in the position shown. [4]

(ii) State and explain whether the ball is in equilibrium.

b. Determine the speed of rotation of the ball. [3]

Markscheme

a. (i) [1] each for correct arrow and (any reasonable) labelling;

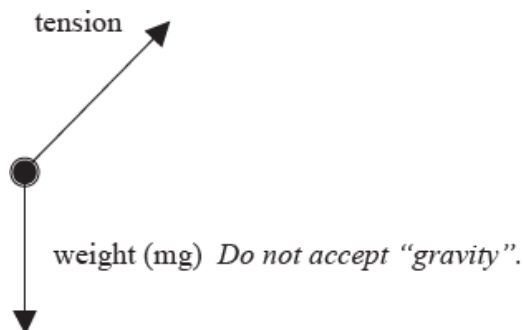

Award [1 max] for arrows in correct direction but not starting at the ball.

(ii) no;

because the two forces on the ball can never cancel out / there is a net force on the ball / the ball moves in a circle / the ball has acceleration/it is changing direction;

Award [0] for correct answer with no or wrong argument.

b. $T \left(= \frac{mg}{\cos 30^\circ} \right) = 2.832\text{N};$

$$\frac{mv^2}{r} = T \sin 30^\circ;$$

$$v = \left(\sqrt{\frac{Tr \sin 30^\circ}{m}} = \sqrt{\frac{2.832 \times 0.33 \times \sin 30^\circ}{0.25}} \right) = 1.4\text{ms}^{-1};$$

or

$$T \cos 30^\circ = mg;$$

$$T \sin 30^\circ = \frac{mv^2}{r};$$

$$v = \left(\sqrt{gr \tan 30^\circ} = \sqrt{9.81 \times 0.33 \times \tan 30^\circ} \right) = 1.4\text{ms}^{-1};$$

Examiners report

- a. [N/A]
b. [N/A]

This question is about kinematics.

Lucy stands on the edge of a vertical cliff and throws a stone vertically upwards.

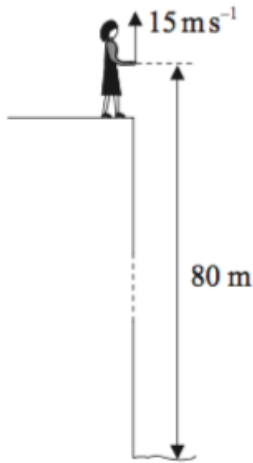

The stone leaves her hand with a speed of 15 ms^{-1} at the instant her hand is 80 m above the surface of the sea. Air resistance is negligible and the acceleration of free fall is 10 ms^{-2} .

- a. Calculate the maximum height reached by the stone as measured from the point where it is thrown. [2]
- b. Determine the time for the stone to reach the surface of the sea after leaving Lucy's hand. [3]

Markscheme

a. $h = \frac{v^2}{2g};$
 $= \left(\frac{225}{20} \right) = 11 \text{ m};$

Award [1 max] for 91 m or 91.25 m (candidate adds cliff height incorrectly).

- b. time to reach maximum height = $1.5 \text{ s};$

time to fall $91 \text{ m} = 4.3 \text{ s};$

total time = $5.8 \text{ s};$

Answer can be alternatively expressed as 3.0 (to return to hand) $+ 2.8$ (to fall 80 m).

or

use of $s = ut + \frac{1}{2}at^2;$

$$80 = -15t + 5t^2 \text{ or } -80 = 15t - 5t^2;$$

$$t = 5.8 \text{ s};$$

Examiners report

- a. The kinematic solutions seen were very pleasing with clear explanations and correct answers. However some candidates added an extra 80 m to the answer having failed to appreciate that the answer should have been “from the point where it [the stone] was thrown”, i.e. the top of the cliff.
- b. Two routes to the answer were seen: a straightforward approach in which both sections of the motion are considered and totalled, and a method using a single determination of a quadratic equation from $s = ut + \frac{1}{2}at^2$. Only about half the candidates using the second route were able to arrive at the answer without error. The first approach was well done by the majority attempting this route.

A glider is an aircraft with no engine. To be launched, a glider is uniformly accelerated from rest by a cable pulled by a motor that exerts a horizontal force on the glider throughout the launch.

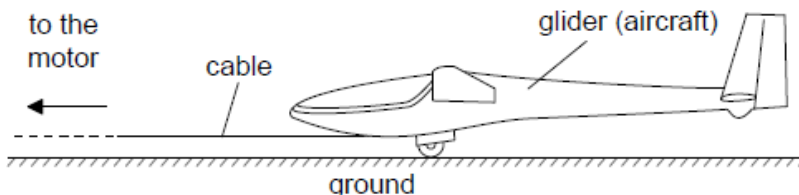

- a. The glider reaches its launch speed of 27.0 m s^{-1} after accelerating for 11.0 s. Assume that the glider moves horizontally until it leaves the ground. Calculate the total distance travelled by the glider before it leaves the ground. [2]
- b. The glider and pilot have a total mass of 492 kg. During the acceleration the glider is subject to an average resistive force of 160 N. Determine the average tension in the cable as the glider accelerates. [3]
- c. The cable is pulled by an electric motor. The motor has an overall efficiency of 23 %. Determine the average power input to the motor. [3]
- d. The cable is wound onto a cylinder of diameter 1.2 m. Calculate the angular velocity of the cylinder at the instant when the glider has a speed of 27 m s^{-1} . Include an appropriate unit for your answer. [2]
- e. After takeoff the cable is released and the unpowered glider moves horizontally at constant speed. The wings of the glider provide a lift force. [2]
- The diagram shows the lift force acting on the glider and the direction of motion of the glider.

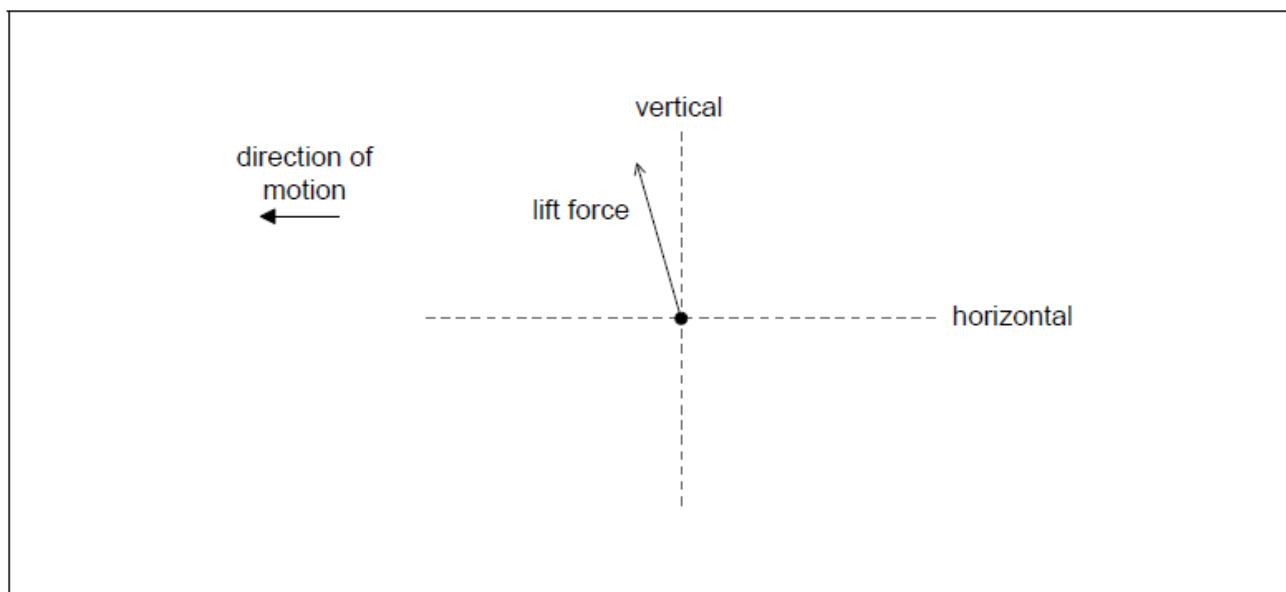

Draw the forces acting on the glider to complete the free-body diagram. The dotted lines show the horizontal and vertical directions.

- f. Explain, using appropriate laws of motion, how the forces acting on the glider maintain it in level flight. [2]
- g. At a particular instant in the flight the glider is losing 1.00 m of vertical height for every 6.00 m that it goes forward horizontally. At this instant, [3]
the horizontal speed of the glider is 12.5 m s^{-1} . Calculate the **velocity** of the glider. Give your answer to an appropriate number of significant figures.

Markscheme

- a. correct use of kinematic equation/equations

148.5 **or** 149 **or** 150 «m»

Substitution(s) must be correct.

- b. $a = \frac{27}{11}$ **or** 2.45 «m s⁻²»

$$F - 160 = 492 \times 2.45$$

1370 «N»

Could be seen in part (a).

Award [0] for solution that uses $a = 9.81 \text{ m s}^{-2}$

- c. **ALTERNATIVE 1**

«work done to launch glider» = 1370×149 «= 204 kJ»

$$\text{«work done by motor»} = \frac{204 \times 100}{23}$$

$$\text{«power input to motor»} = \frac{204 \times 100}{23} \times \frac{1}{11} = 80 \text{ **or** } 80.4 \text{ **or** } 81 \text{ k«W»}$$

ALTERNATIVE 2

use of average speed 13.5 m s^{-1}

«useful power output» = force x average speed «= 1370×13.5 »

$$\text{power input} = \text{«}1370 \times 13.5 \times \frac{100}{23} \text{»} \Rightarrow 80 \text{ **or** } 80.4 \text{ **or** } 81 \text{ k«W»}$$

ALTERNATIVE 3

work required from motor = KE + work done against friction «= $0.5 \times 492 \times 27^2 + (160 \times 148.5)$ » = 204 «kJ»

$$\text{«energy input»} = \frac{\text{work required from motor} \times 100}{23}$$

$$\text{power input} = \frac{883000}{11} = 80.3 \text{ k«W»}$$

Award [2 max] for an answer of 160 k«W».

- d. $\omega = \frac{v}{r} \Rightarrow \frac{27}{0.6} = 45$

rad s⁻¹

Do not accept Hz.

Award [1 max] if unit is missing.

- e. direction of motion
←

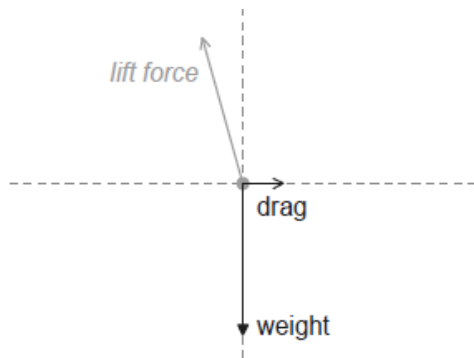

drag correctly labelled and in correct direction

weight correctly labelled and in correct direction **AND** no other incorrect force shown

Award [1 max] if forces do not touch the dot, but are otherwise OK.

- f. name Newton's first law

vertical/all forces are in equilibrium/balanced/add to zero

OR

vertical component of lift mentioned

as equal to weight

- g. any speed and any direction quoted together as the answer

quotes their answer(s) to 3 significant figures

speed = 12.7 m s^{-1} **or** direction = 9.46° **or** 0.165 rad «below the horizontal» **or** gradient of $-\frac{1}{6}$

Examiners report

- a. [N/A]
b. [N/A]
c. [N/A]
d. [N/A]
e. [N/A]
f. [N/A]
g. [N/A]

This question is about kinematics.

- a. State the difference between average speed and instantaneous speed.

[2]

- b. The graph shows how the acceleration a of a particle varies with time t .

[3]

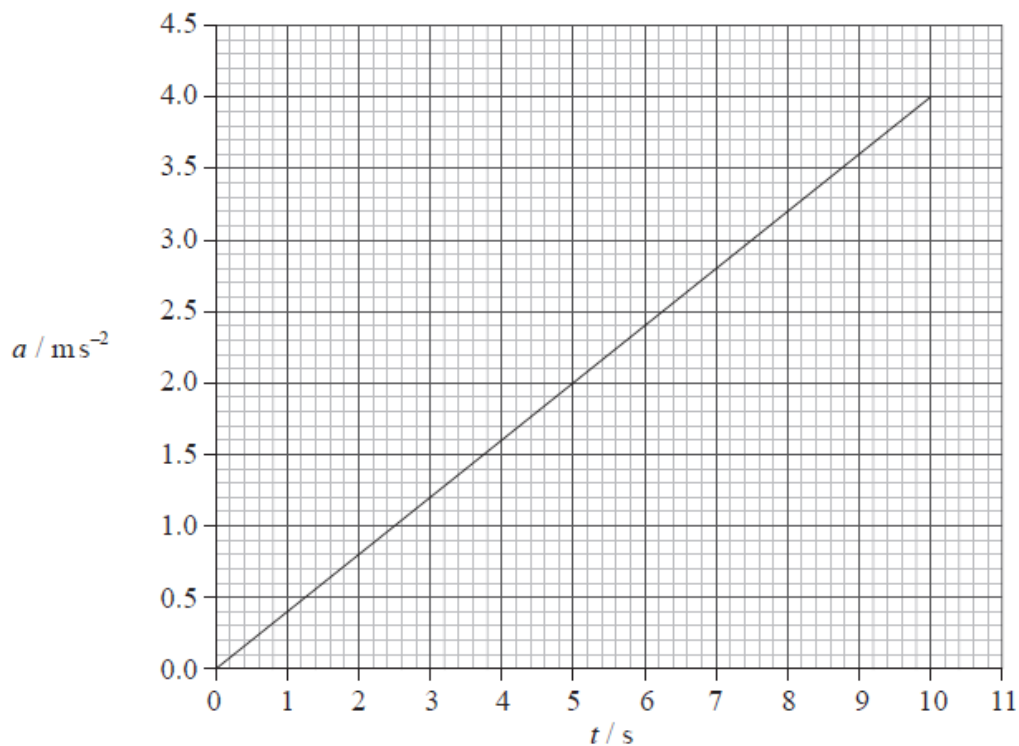

At time $t = 0$ the instantaneous speed of the particle is zero.

(i) Calculate the instantaneous speed of the particle at $t = 7.5$ s.

(ii) Using the axes below, sketch a graph to show how the instantaneous speed v of the particle varies with t .

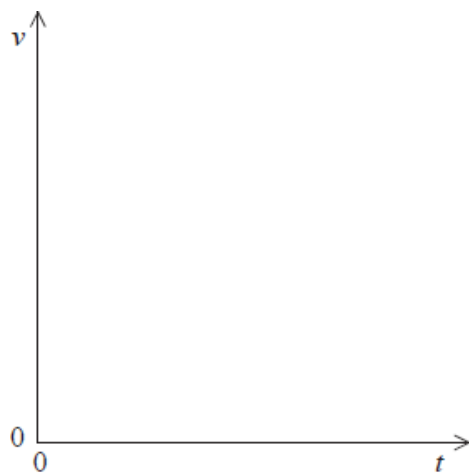

Markscheme

a. average speed is the speed over a period of time/distance; instantaneous speed is the speed at a particular instant in time/point in space.

b. (i) speed=(area under graph \Rightarrow) $\frac{1}{2} \times 7.5 \times 3$;

=10 **or** 11 **or** 11.3 (ms^{-1});

(ii) suitable curve approximating to $v=kt^2$;

Examiners report

a. As in the previous question, candidates appeared to understand the distinction between average and instantaneous speeds but could not express a concise or (sometimes) meaningful account. Some good answers were seen that used calculus ideas but this was not required by the examiners.

b. (i) Candidates were required to recognize that the area under an acceleration–time graph yields the speed change of a particle. They were also expected to give a realistic number of significant figures in their answer. This trapped very many.

(ii) A very large majority of candidates were able to give a good sketch of a parabola for their answer. Failing answers included a straight line through the origin and a straight line parallel to the x -axis.

This question is in **two** parts. **Part 1** is about mechanics and thermal physics. **Part 2** is about nuclear physics.

Part 1 Mechanics and thermal physics

The graph shows the variation with time t of the speed v of a ball of mass 0.50 kg, that has been released from rest above the Earth's surface.

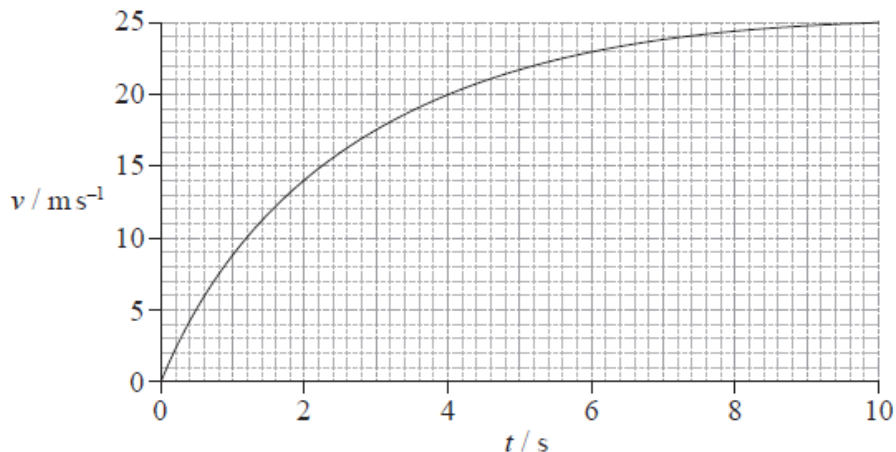

The force of air resistance is **not** negligible. Assume that the acceleration of free fall is $g = 9.81 \text{ ms}^{-2}$.

a. State, without any calculations, how the graph could be used to determine the distance fallen. [1]

b. (i) In the space below, draw and label arrows to represent the forces on the ball at 2.0 s. [7]

ball at
 $t = 2.0 \text{ s}$ ●

Earth's surface —————

- (ii) Use the graph opposite to show that the acceleration of the ball at 2.0 s is approximately 4 ms^{-2} .
- (iii) Calculate the magnitude of the force of air resistance on the ball at 2.0 s.
- (iv) State and explain whether the air resistance on the ball at $t = 5.0 \text{ s}$ is smaller than, equal to **or** greater than the air resistance at $t = 2.0 \text{ s}$.

c. After 10 s the ball has fallen 190 m. [6]

- (i) Show that the sum of the potential and kinetic energies of the ball has decreased by 780 J.
- (ii) The specific heat capacity of the ball is $480 \text{ J kg}^{-1} \text{ K}^{-1}$. Estimate the increase in the temperature of the ball.
- (iii) State an assumption made in the estimate in (c)(ii).

Markscheme

- a. the area under the curve;
- b. (i) arrows as shown, with up arrow shorter;

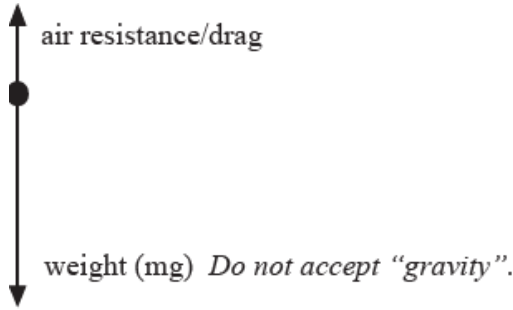

(ii) drawing of tangent to curve at $t = 2.0$ s;
calculation of slope of tangent in range $3.6 - 4.4\text{ms}^{-2}$;
Award [0] for calculations without a tangent but do not be particular about size of triangle.

(iii) calculation of $F = ma = 0.50 \times 4 = 2\text{N}$
 $R (= mg - ma = 0.50 \times 9.81 - 0.50 \times 4) \approx 3\text{N}$;

(iv) the acceleration is decreasing;
and so R is greater;

or

air resistance forces increase with speed;
since speed at 5.0 s is greater so is resistance force;

- c. (i) loss of potential energy is $mg\Delta h = 0.50 \times 9.81 \times 190 = 932\text{J}$;

gain in kinetic energy is $\frac{1}{2}mv^2 = \frac{1}{2}0.50 \times 25^2 = 156\text{J}$;

loss of mechanical energy is $932 - 156$;

$\approx 780\text{J}$

(ii) $mc\Delta\theta = 780\text{J}$;

$\Delta\theta = \left(\frac{780}{0.5 \times 480}\right) \approx 3\text{K}/3^\circ\text{C}$;

(iii) all the lost energy went into heating just the ball / no energy transferred to surroundings / the ball was heated uniformly;

Examiners report

- a. [N/A]
b. [N/A]
c. [N/A]

This question is in **two** parts. **Part 1** is about a collision. **Part 2** is about electric current and resistance.

Part 1 A collision

Two identical blocks of mass 0.17kg and length 0.050m are travelling towards each other along a straight line through their centres as shown below. Assume that the surface is frictionless.

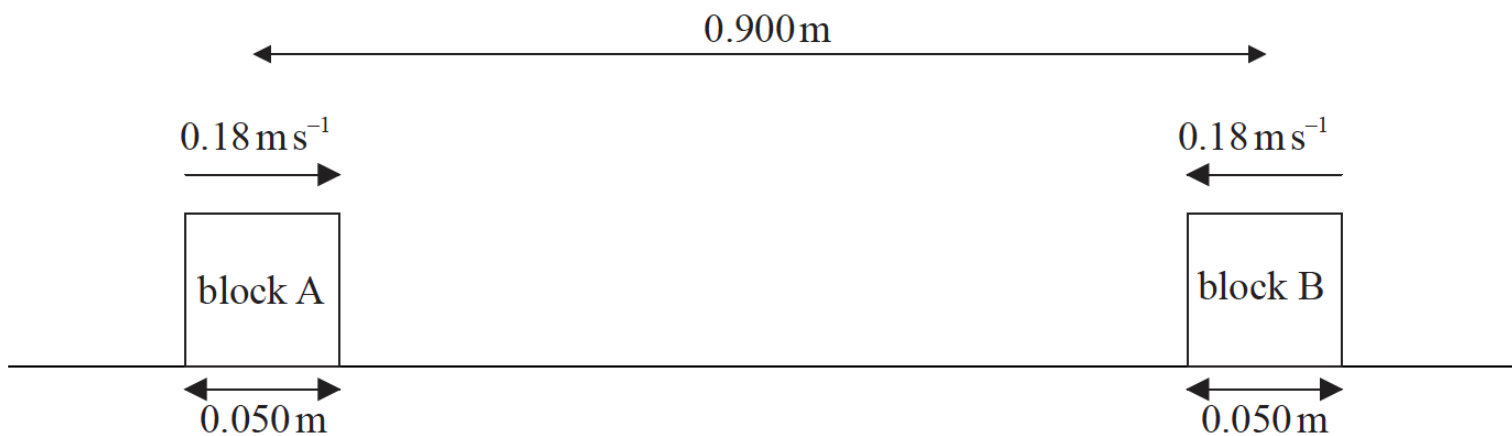

The initial distance between the centres of the blocks is 0.900 m and both blocks are moving at a speed of 0.18 ms^{-1} relative to the surface.

- a. Determine the time taken for the blocks to come into contact with each other. [3]
- b. As a result of the collision, the blocks reverse their direction of motion and travel at the same speed as each other. During the collision, 20% of the kinetic energy of the blocks is given off as thermal energy to the surroundings. [5]
- (i) State and explain whether the collision is elastic or inelastic.
- (ii) Show that the final speed of the blocks relative to the surface is 0.16 m s^{-1} .
- c. (i) State Newton's third law of motion. [7]
- (ii) During the collision of the blocks, the magnitude of the force that block A exerts on block B is F_{AB} and the magnitude of the force that block B exerts on block A is F_{BA} . On the diagram below, draw labelled arrows to represent the magnitude and direction of the forces F_{AB} and F_{BA} .

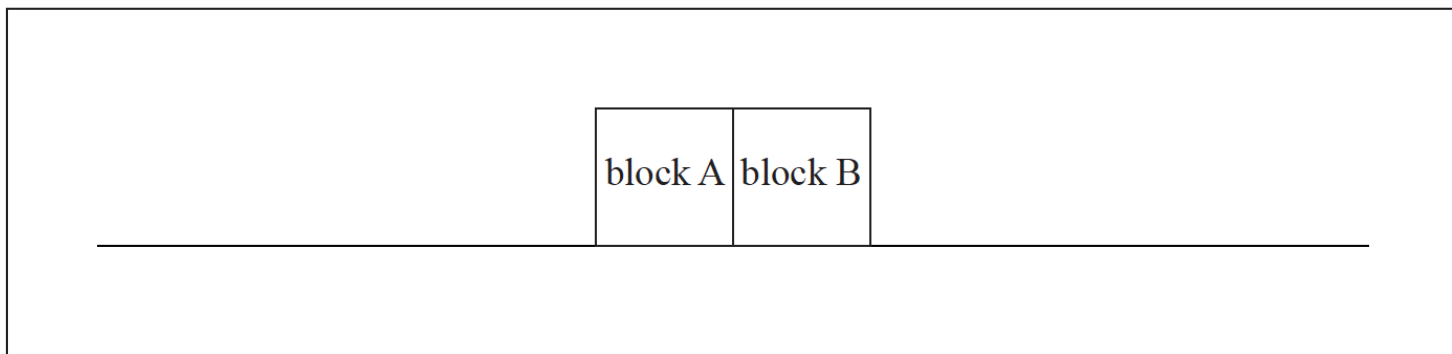

- (iii) The duration of the collision between the blocks is 0.070 s . Determine the average force one block exerted on the other.

Markscheme

- a. distance between surfaces of blocks = $0.900 - 0.050 = 0.850 \text{ m}$;

relative speed between blocks = 0.36 ms^{-1} ;

$$\text{time} = \frac{\text{distance}}{\text{speed}} = \frac{0.850}{0.36} = 2.4 \text{ s};$$

or

blocks moving at same speed so meet at mid-point;

distance travelled by block = $0.450 - 0.025 = 0.425 \text{ m}$;

$$\text{time} = \frac{\text{distance}}{\text{speed}} = \frac{0.425}{0.18} = 2.4 \text{ s};$$

Award [3] for bald correct answer.

Award [2 max] if distance of 0.90 m or 0.45 m used to get 2.5 s .

b. (i) the collision is inelastic;

because kinetic energy is not conserved (although momentum is);

$$(ii) \text{ initial } E_K = \frac{1}{2} \times 0.17 \times 0.18^2 = 0.002754\text{J};$$

$$\text{final } E_K = 0.80 \times 0.002754 = 0.0022032\text{J};$$

$$\text{final speed} = \sqrt{\frac{2 \times 0.0022032}{0.17}};$$

$$= 0.16\text{ms}^{-1}$$

or

$$0.8 \times \text{initial } E_K = \text{final } E_K;$$

$$0.8 \times \frac{1}{2} \times 0.17 \times 0.18^2 = \frac{1}{2} \times 0.17 \times v^2;$$

$$v = \sqrt{0.8 \times 0.18^2};$$

$$= 0.16\text{ms}^{-1}$$

c. (i) if object A exerts a force on object B, then object B (simultaneously) exerts an equal and opposite force on object A / every action has an equal and opposite reaction / *OWTTE*;

(ii) arrows of equal length; (*judge by eye*)
acting through centre of blocks;
correct labelling consistent with correct direction;

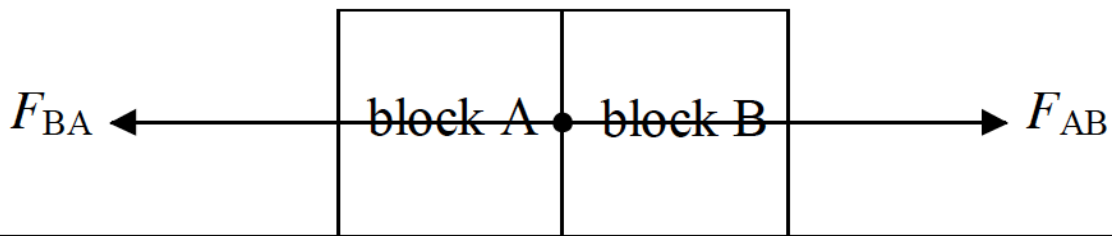

$$(iii) \Delta v = 0.16 - (-0.18) = 0.34\text{ms}^{-1};$$

$$a = \frac{\Delta v}{\Delta t} = \frac{0.34}{0.070} = 4.857\text{ms}^{-2};$$

$$F = ma = 0.17 \times 4.857 = 0.83\text{N};$$

or

$$\Delta v = 0.16 - (-0.18) = 0.34\text{ms}^{-1};$$

$$\text{impulse} = F\Delta t = m\Delta v \Rightarrow F = \frac{0.17 \times 0.34}{0.07};$$

$$F = 0.83\text{N};$$

Examiners report

a. [N/A]

b. [N/A]

c. [N/A]

This question is about the motion of a bicycle.

A cyclist is moving up a slope that is at an angle of 19° to the horizontal. The mass of the cyclist and the bicycle is 85 kg.

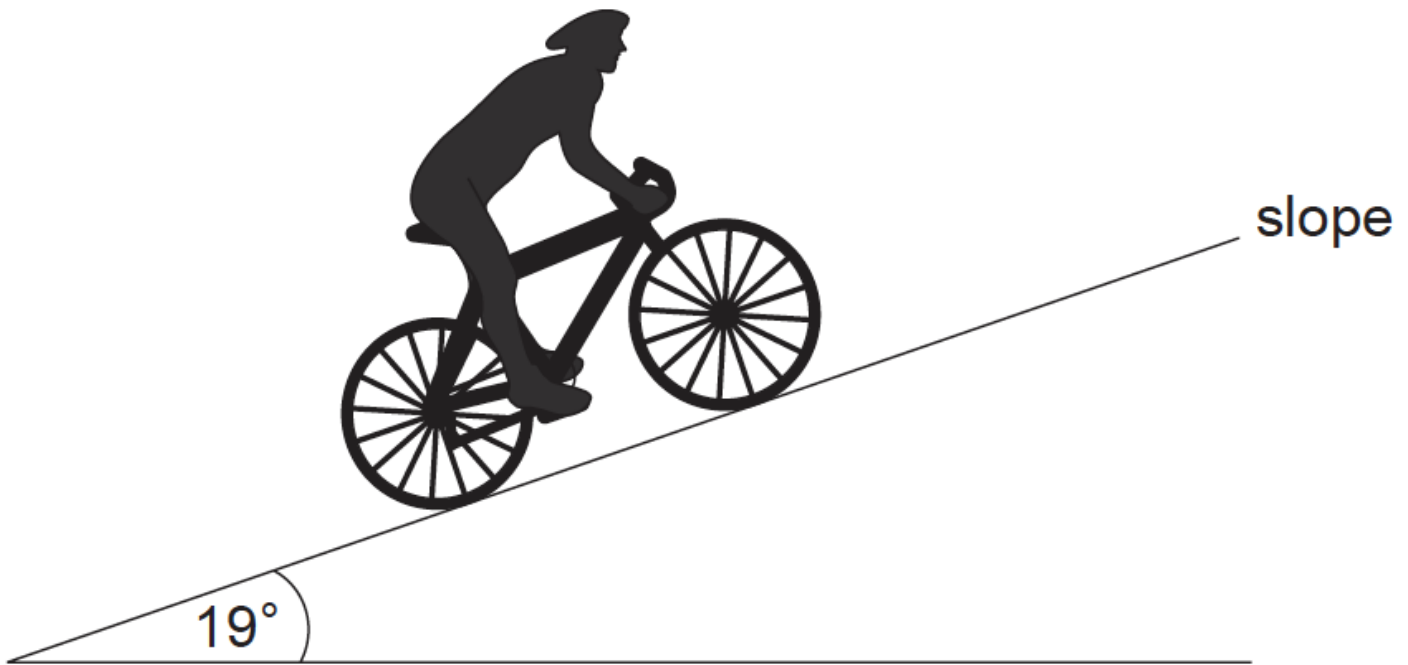

- a. Calculate the [3]
- (i) component of the weight of the cyclist and bicycle parallel to the slope.
 - (ii) normal reaction force on the bicycle from the slope.
- b. At the bottom of the slope the cyclist has a speed of 5.5ms^{-1} . The cyclist stops pedalling and applies the brakes which provide an additional [4]
decelerating force of 250 N. Determine the distance taken for the cyclist to stop. Assume air resistance is negligible and that there are no other frictional forces.

Markscheme

- a. (i) (weight) = $85 \times 9.81 (=834\text{N})$; (if 850 (N) seen, award this mark)

component = $(834 \times \sin 19) = 271$ (N);

Allow use of $g=10\text{ms}^{-2}$. Answer is 277 (N).

(ii) component = $(834 \times \cos 19) = 788$ (N);

Allow use of $g=10\text{ms}^{-2}$. Answer is 804 (N).

Allow a bald correct answer.

Do not award ECF if cos used in (a)(i) and sin used in (a)(ii).

- b. total decelerating force = $271 + 250 (=521\text{N})$;

acceleration = $(-) \frac{521}{85} (= -6.13\text{ms}^{-2})$;

$$s = \frac{v^2 - u^2}{2a};$$

2.47 (m); (signs must be consistent for this mark, ie: if acceleration assumed positive, look for negative distance)

Allow use of $g=10$. Answers are 527 N, 6.2ms^{-2} , 2.44 m.

or

total decelerating force = $271 + 250 (= 521 \text{ N})$;

initial kinetic energy = $\frac{1}{2}mv^2 = 1290 \text{ J}$

distance = $\frac{\text{energy lost}}{\text{force}} = \frac{1290}{521}$

2.47 (m);

Examiners report

a. [N/A]

b. [N/A]

a. Define *electric field strength*. [2]

b. The diagram shows a pair of horizontal metal plates. Electrons can be deflected vertically using an electric field between the plates. [5]

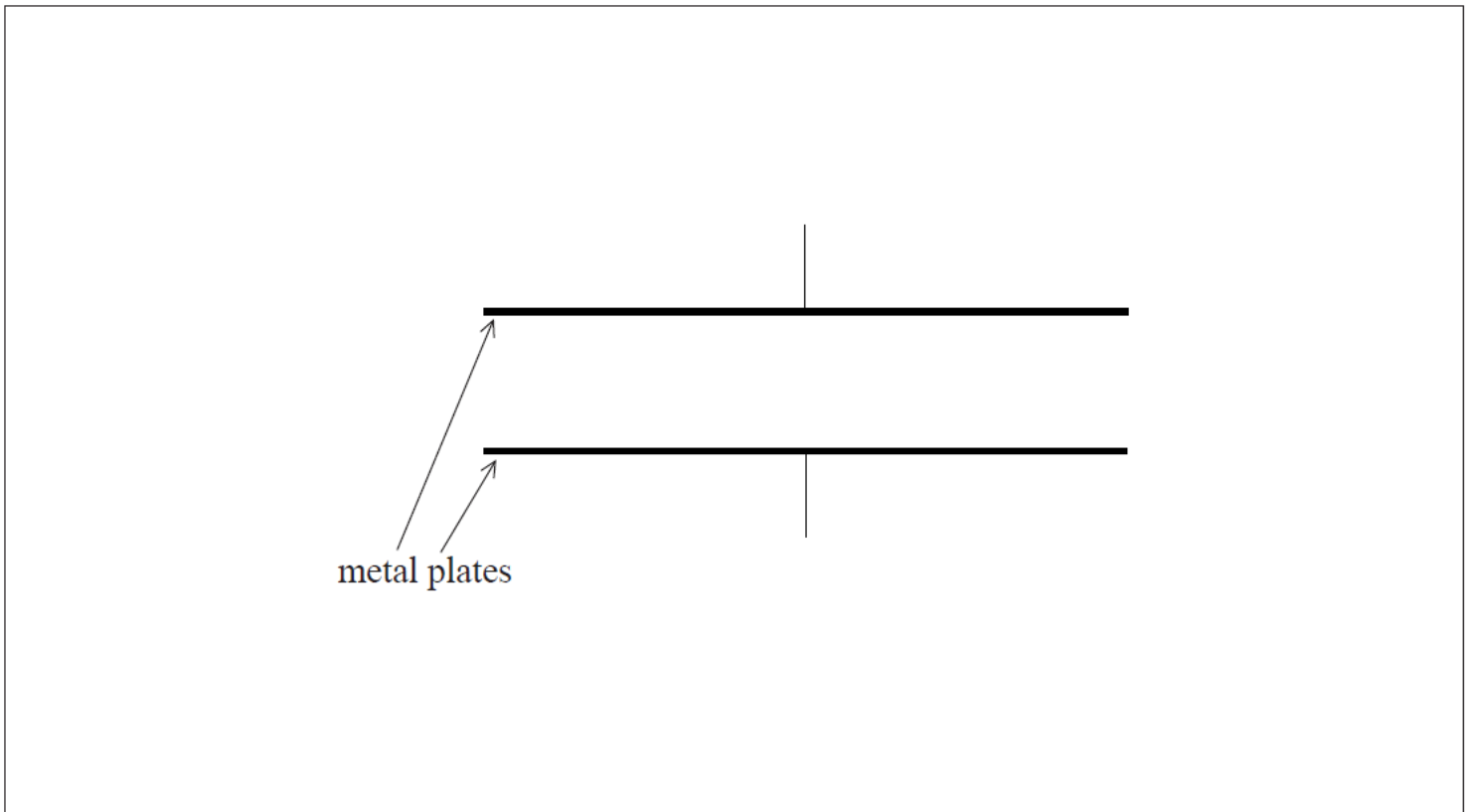

(i) Label, on the diagram, the polarity of the metal plates which would cause an electron positioned between the plates to accelerate upwards.

(ii) Draw the shape and direction of the electric field between the plates on the diagram.

(iii) Calculate the force on an electron between the plates when the electric field strength has a value of $2.5 \times 10^3 \text{ NC}^{-1}$.

c. The diagram shows two isolated electrons, X and Y, initially at rest in a vacuum. The initial separation of the electrons is 5.0 mm. The electrons subsequently move apart in the directions shown. [8]

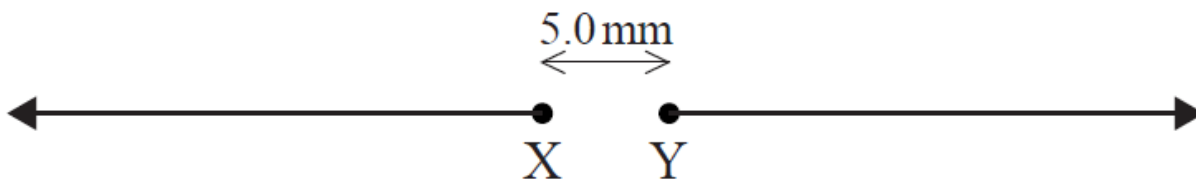

(i) Show that the initial electric force acting on each electron due to the other electron is approximately $9 \times 10^{-24}\text{N}$.

(ii) Calculate the initial acceleration of one electron due to the force in (c)(i).

(iii) Discuss the motion of one electron after it begins to move.

(iv) The diagram shows Y as seen from X, at one instant. Y is moving into the plane of the paper. For this instant, draw on the diagram the shape and direction of the magnetic field produced by Y.

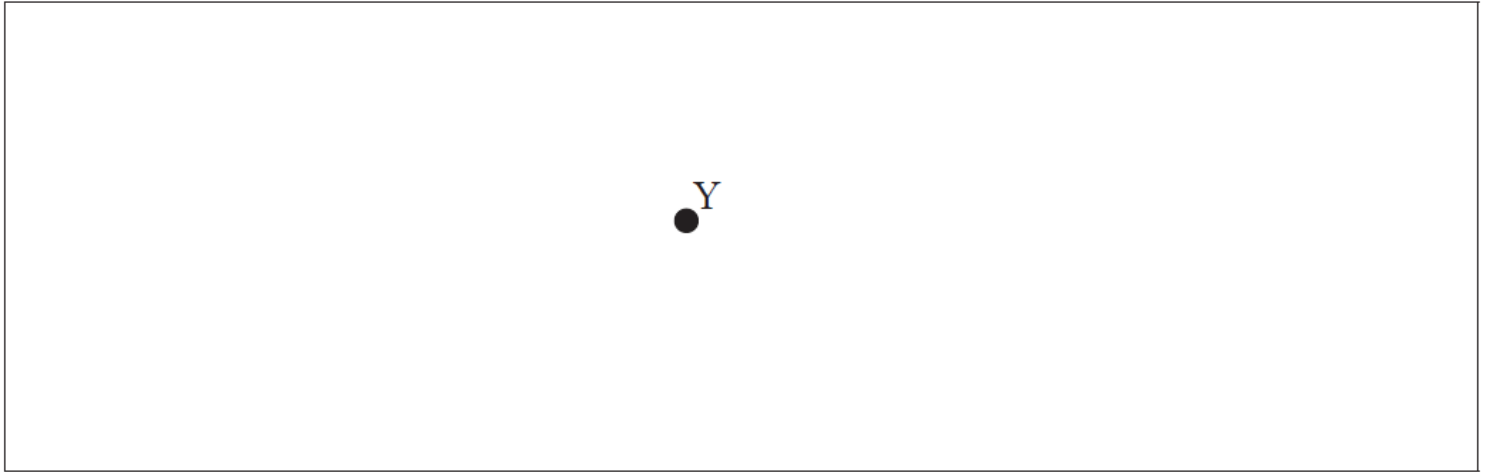

Markscheme

a. force per unit charge;

on a positive test charge / on a positive small charge;

b. (i) top plate positive and bottom negative (or +/- and ground);

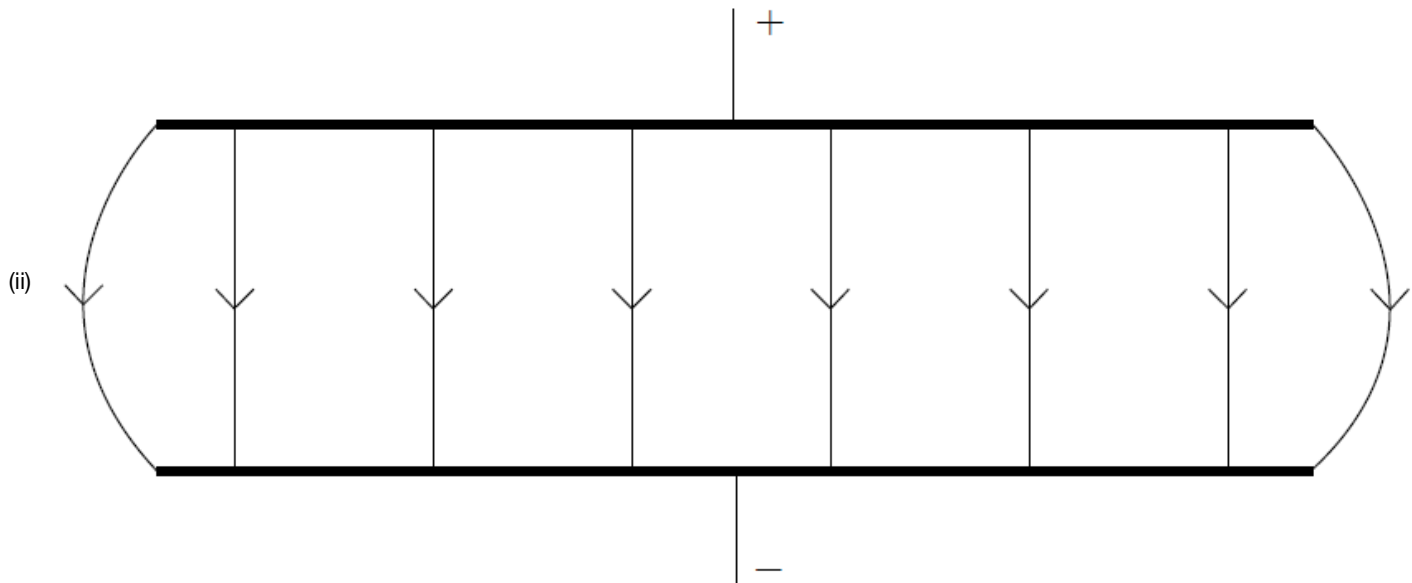

uniform (by eye) line spacing and edge effect, field lines touching both plates;

downward arrows (minimum of one and none upward);

(iii) $F = 2.5 \times 10^3 \times 1.6 \times 10^{-19}$
 4.0×10^{-16} (N);

Award [2] for a bald correct answer.

c. (i) use of $F = \frac{(1.60 \times 10^{-19})^2}{4\pi\epsilon_0(5.0 \times 10^{-3})^2}$ or $F = \frac{(1.60 \times 10^{-19})^2}{(5.0 \times 10^{-3})^2} \times 8.99 \times 10^9$;

$9.2 \times 10^{-24} \text{ (N)}$;

(ii) $1.0 \times 10^7 \text{ (ms}^{-2}\text{)}$ ($9.9 \times 10^6 \text{ (ms}^{-2}\text{)}$ if $9 \times 10^{-24} \text{ (N)}$ used);

(iii) electron will continue to accelerate;

speed increases with acceleration;

acceleration reduces with separation;

when outside the field no further acceleration/constant speed;

any reference to accelerated charge radiating and losing (kinetic) energy;

(iv) minimum of two concentric circles centred on Y;

anti-clockwise;

Examiners report

- a. (i) As this is worth two marks, candidates should see the signal that force per unit charge is unlikely to gain full marks; and so it proved. Although a mark was available for saying this there needed to be a reference to the charge being a positive test charge.
- b. (i) G2 comments that the term 'polarity' was confusing to candidates proved to be unfounded and nearly all candidates marked in a positive and negative terminal – although the actual polarity was often incorrect.
- (ii) With error carried forwards, the direction of the field was often correct but the drawing often was below an acceptable standard with line of force not bridging the plates, being very unevenly spaced and having no edge effect.
- (iii) This calculation was almost invariably very well done.
- c. (i) In another 'show that' question it was expected that candidates would use Coulombs law and the data value for the electronic charge to give a value of more than one digit; often this was not the case but otherwise this was generally well done
- (ii) Most candidates used their value for the force (or $9 \times 10^{-24} \text{ N}$) and the mass of the electron on the data sheet to calculate a correct value for the acceleration.
- (iii) This was an unusual opportunity for candidates to use Newton's laws and many did say that the acceleration would decrease with distance. Too often they incorrectly believed that this meant that the electron would slow down – it continues to accelerate but at an ever decreasing rate.
- (iv) Clearly, this part represented a simplification of a complex situation but as set up was not beyond the skills of most of the candidates. The electron represents an instant in which a conventional current would leave the page and the field at this instant would be that of concentric circles with an anti-clockwise (counter-clockwise) direction. Many candidates did draw this but diagrams were too frequently hurriedly drawn and of a poor standard.

This question is about kinematics.

- a. Fiona drops a stone from rest vertically down a water well. She hears the splash of the stone striking the water 1.6 s after the stone leaves her hand. Estimate the [3]

(i) distance between Fiona's hand and the water surface.

(ii) speed with which the stone hits the water.

- b. After the stone in (a) hits the water surface it rapidly reaches a terminal speed as it falls through the water. The stone leaves Fiona's hand at time $t = 0$. It hits the water surface at t_1 and it comes to rest at the bottom of the water at t_2 . Using the axes below, sketch a graph to show how the speed v of the stone varies from time $t = 0$ to just before $t = t_2$. (There is no need to add any values to the axes.)

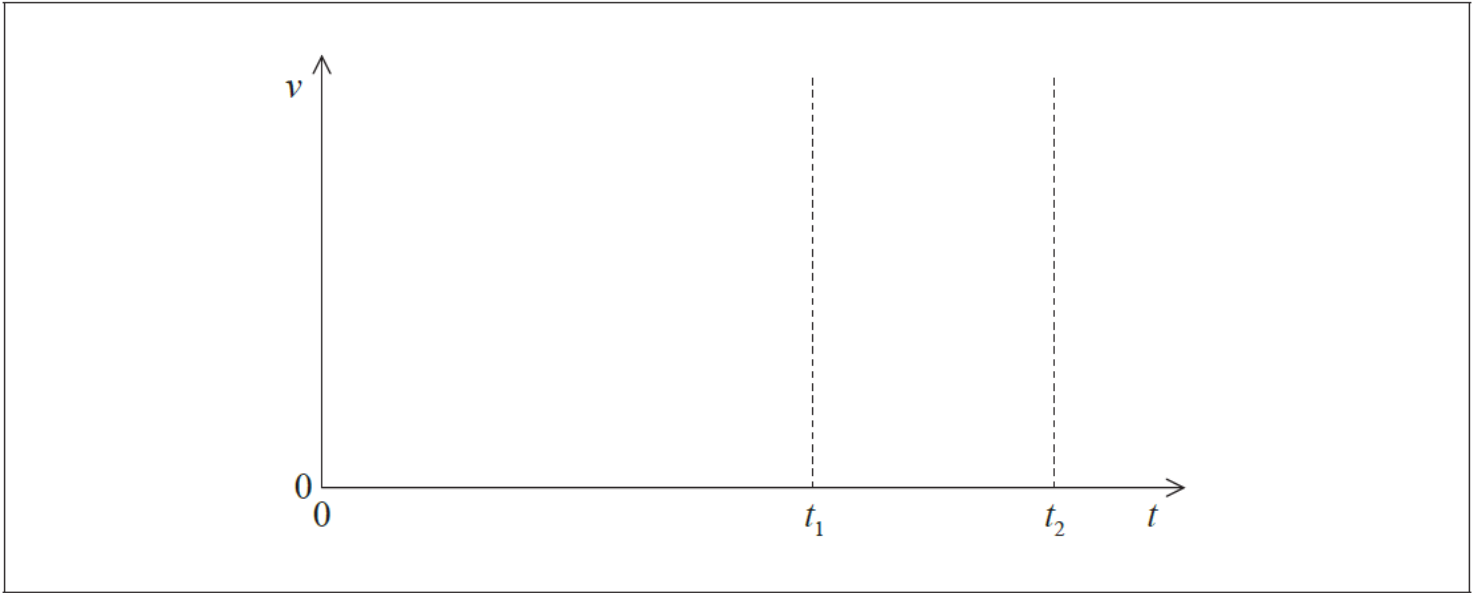

- c. Draw and label a free-body diagram representing the forces acting on the stone as it falls through the water at its terminal speed.

[2]

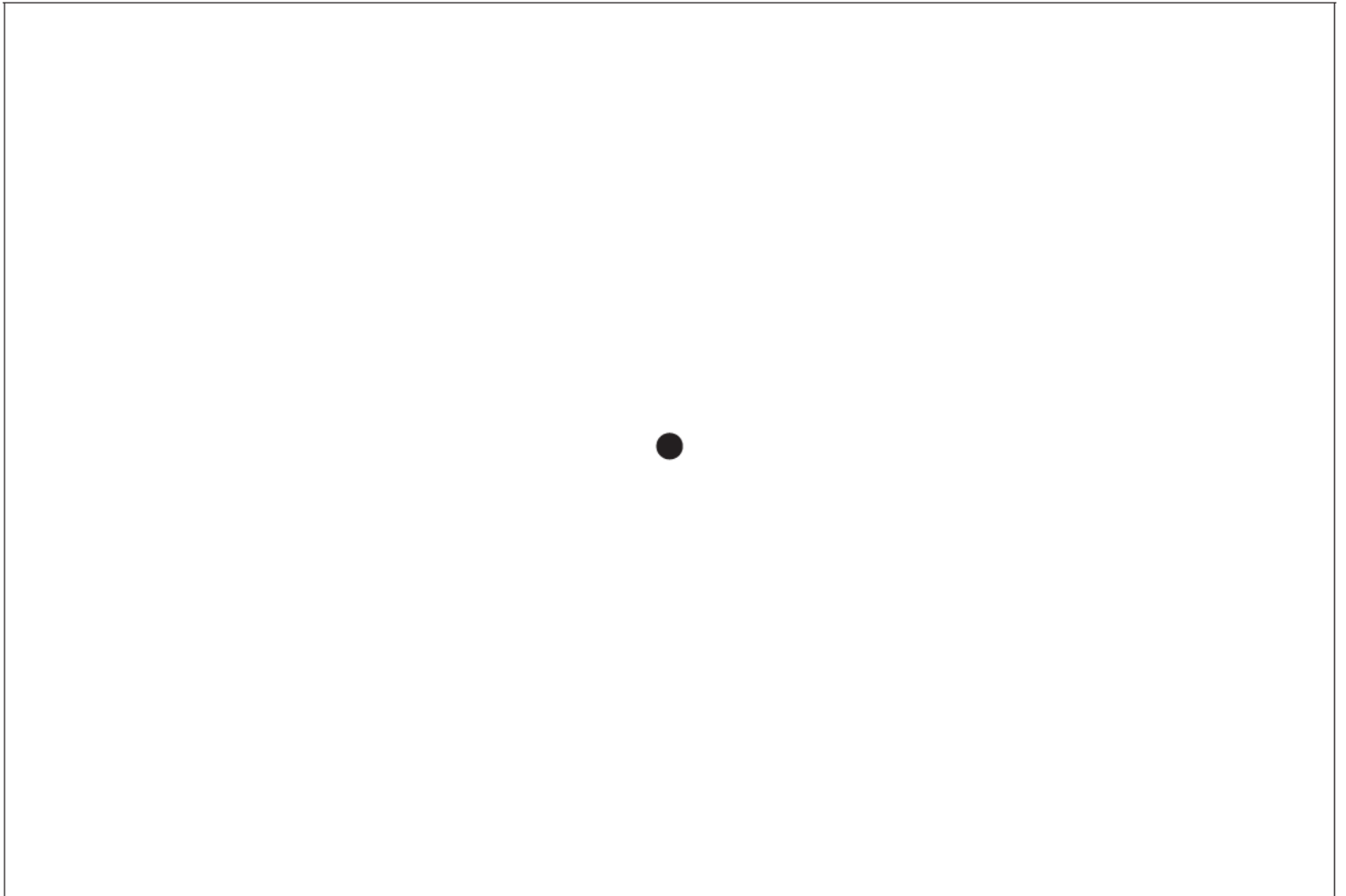

Markscheme

a. (i) $s=12.5/12.6$ (m);

Allow $g = 10\text{ms}^{-2}$, answer is 12.8.

(ii) $v = \sqrt{2gs}$ or gt ; (allow any use of suvat equations)

$$= (\sqrt{2 \times 9.8 \times 12.5}) = 15.7 \text{ (ms}^{-1}\text{)};$$

Award **[2]** for a bald correct answer.

Allow $g = 10\text{ms}^{-2}$ answer is 16.0 ms^{-1} .

Allow ECF from (a)(i)

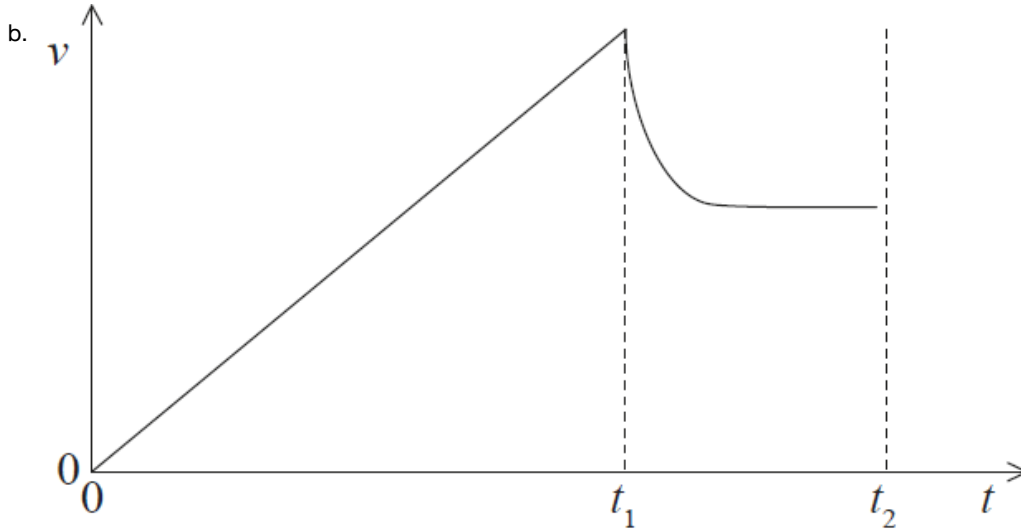

straight line to water surface; (allow a slight curve within 10 % of t_1) clear decrease after hitting surface; (allow straight line or concave curve as shown, do not allow convex curve)

constant non-zero speed reached smaller than maximum; (speed must be less than maximum velocity)

Do not penalize answers where a curve is drawn to the dotted lines as there should not be a discontinuity at the two lines. Do not penalize if the line continues to t_2 or zero velocity shown at t_2 .

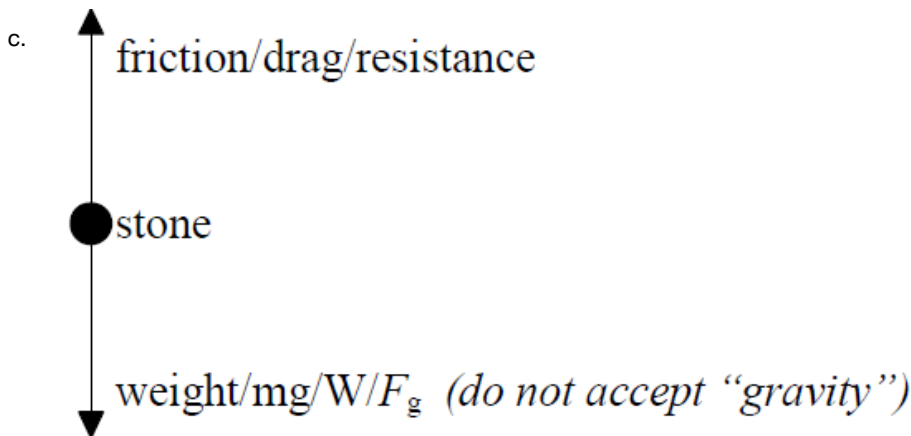

correctly labelled forces;

correct direction and equal lengths; (judge by eye)

Accept co-linear/vector arrows that do not begin at the stone.

Accept arrow heads finalizing at the stone.

Treat mention of upthrust as neutral.

Examiners report

- a. (i) and (ii) These were high scoring questions with a substantial number of correct solutions. Even those who could not answer (i) were able to take their incorrect value and use it correctly in (ii).
- b. This part was not straightforward and demands some thought by candidates – ideally before they put pen to paper. A number of candidates achieved two marks. Common faults included: setting the final speed in the water at higher than the final speed in air; a significantly curved first section before t_1 ; incorrect curvature between t_1 and t_2 and lack of a final constant speed or a zero final speed.
- c. This straightforward question was not well done. Many candidates did not draw two clear lines of appropriate length with a ruler – crude, free-hand sketches were very common. The question asks for labelling and this should be done with words, not symbols. Mention of up thrust was not required in the answer, although its inclusion was treated as neutral.

A student investigates how light can be used to measure the speed of a toy train.

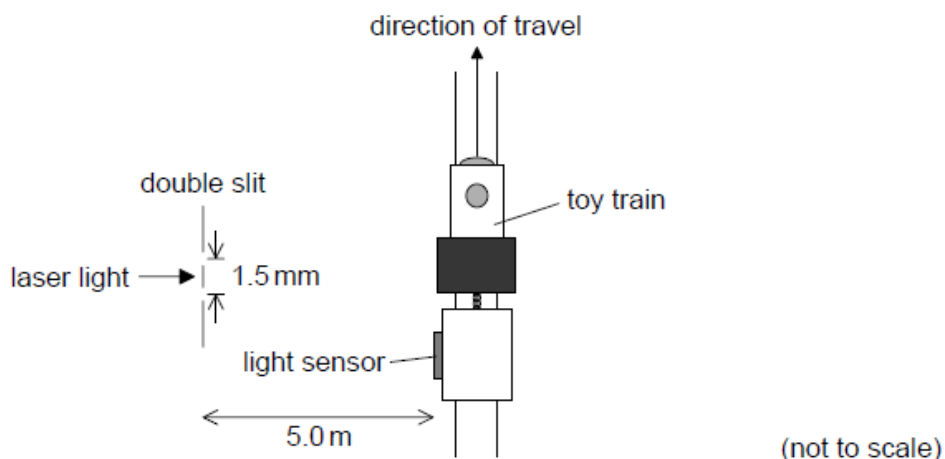

Light from a laser is incident on a double slit. The light from the slits is detected by a light sensor attached to the train.

The graph shows the variation with time of the output voltage from the light sensor as the train moves parallel to the slits. The output voltage is proportional to the intensity of light incident on the sensor.

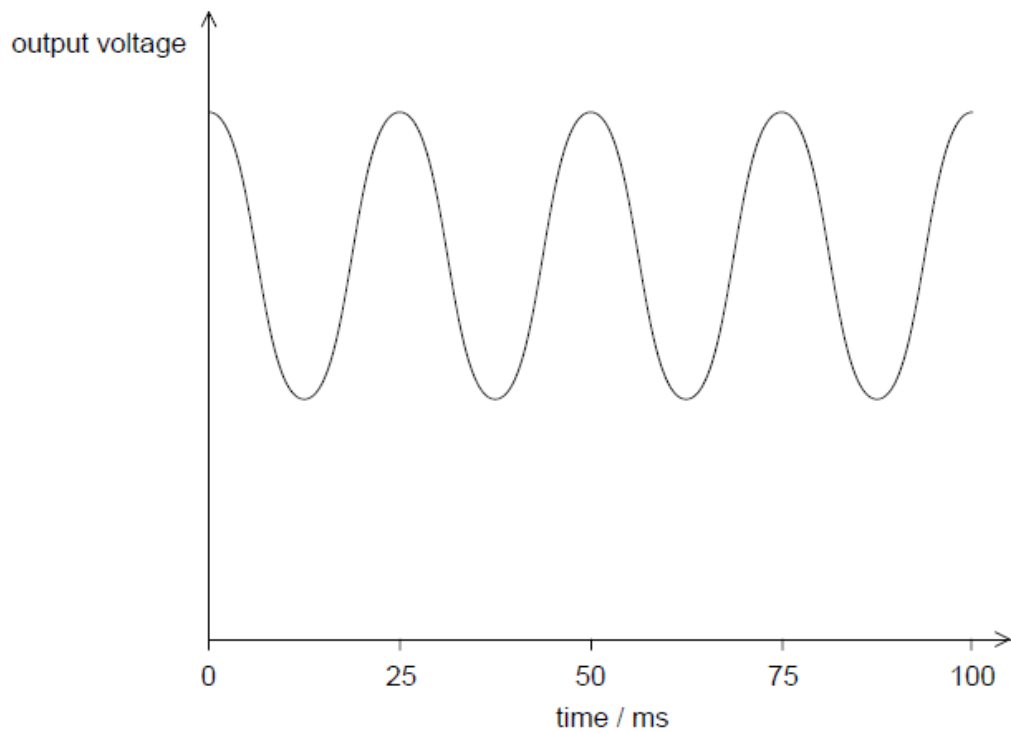

- a. Explain, with reference to the light passing through the slits, why a series of voltage peaks occurs. [3]
- b.i. The slits are separated by 1.5 mm and the laser light has a wavelength of 6.3×10^{-7} m. The slits are 5.0 m from the train track. Calculate the separation between two adjacent positions of the train when the output voltage is at a maximum. [1]
- b.ii. Estimate the speed of the train. [2]
- c. In another experiment the student replaces the light sensor with a sound sensor. The train travels away from a loudspeaker that is emitting sound waves of constant amplitude and frequency towards a reflecting barrier. [2]

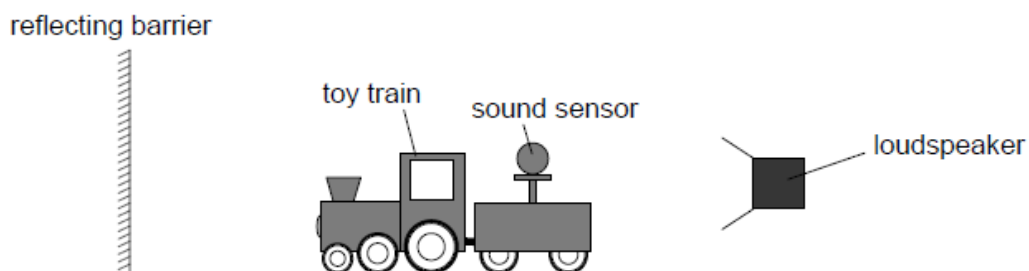

The sound sensor gives a graph of the variation of output voltage with time along the track that is similar in shape to the graph shown in the resource. Explain how this effect arises.

Markscheme

- a. «light» superposes/interferes

pattern consists of «intensity» maxima and minima

OR

consisting of constructive and destructive «interference»

voltage peaks correspond to interference maxima

b.i. $s = \frac{\lambda D}{d} = \frac{6.3 \times 10^{-7} \times 5.0}{1.5 \times 10^{-3}} \Rightarrow 2.1 \times 10^{-3}$ «m»

If no unit assume m.
Correct answer only.

b.ii.correct read-off from graph of 25 m s

$$v = \frac{x}{t} = \frac{2.1 \times 10^{-3}}{25 \times 10^{-3}} \Rightarrow 8.4 \times 10^{-2} \text{ «m s}^{-1}\text{»}$$

Allow ECF from (b)(i)

c. **ALTERNATIVE 1**

«reflection at barrier» leads to two waves travelling in opposite directions

mention of formation of standing wave

maximum corresponds to antinode/maximum displacement «of air molecules»

OR

complete cancellation at node position

Examiners report

- a. [N/A]
- b.i. [N/A]
- b.ii. [N/A]
- c. [N/A]

A company designs a spring system for loading ice blocks onto a truck. The ice block is placed in a holder H in front of the spring and an electric motor compresses the spring by pushing H to the left. When the spring is released the ice block is accelerated towards a ramp ABC. When the spring is fully decompressed, the ice block loses contact with the spring at A. The mass of the ice block is 55 kg.

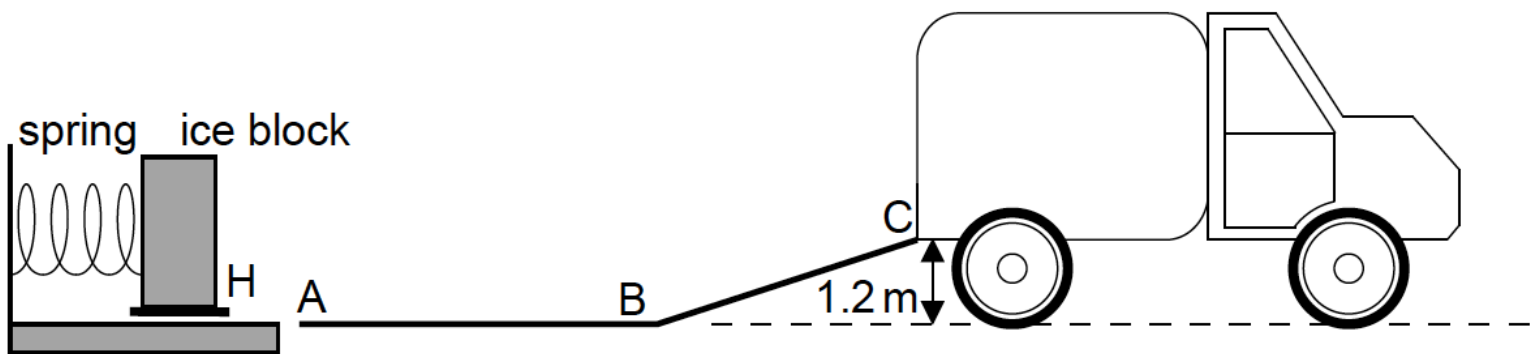

Assume that the surface of the ramp is frictionless and that the masses of the spring and the holder are negligible compared to the mass of the ice block.

- a. (i) The block arrives at C with a speed of 0.90ms^{-1} . Show that the elastic energy stored in the spring is 670J. [4]
- (ii) Calculate the speed of the block at A.
- b. Describe the motion of the block [3]
- (i) from A to B with reference to Newton's first law.

(ii) from B to C with reference to Newton's second law.

- c. On the axes, sketch a graph to show how the displacement of the block varies with time from A to C. (You do not have to put numbers on the axes.) [2]

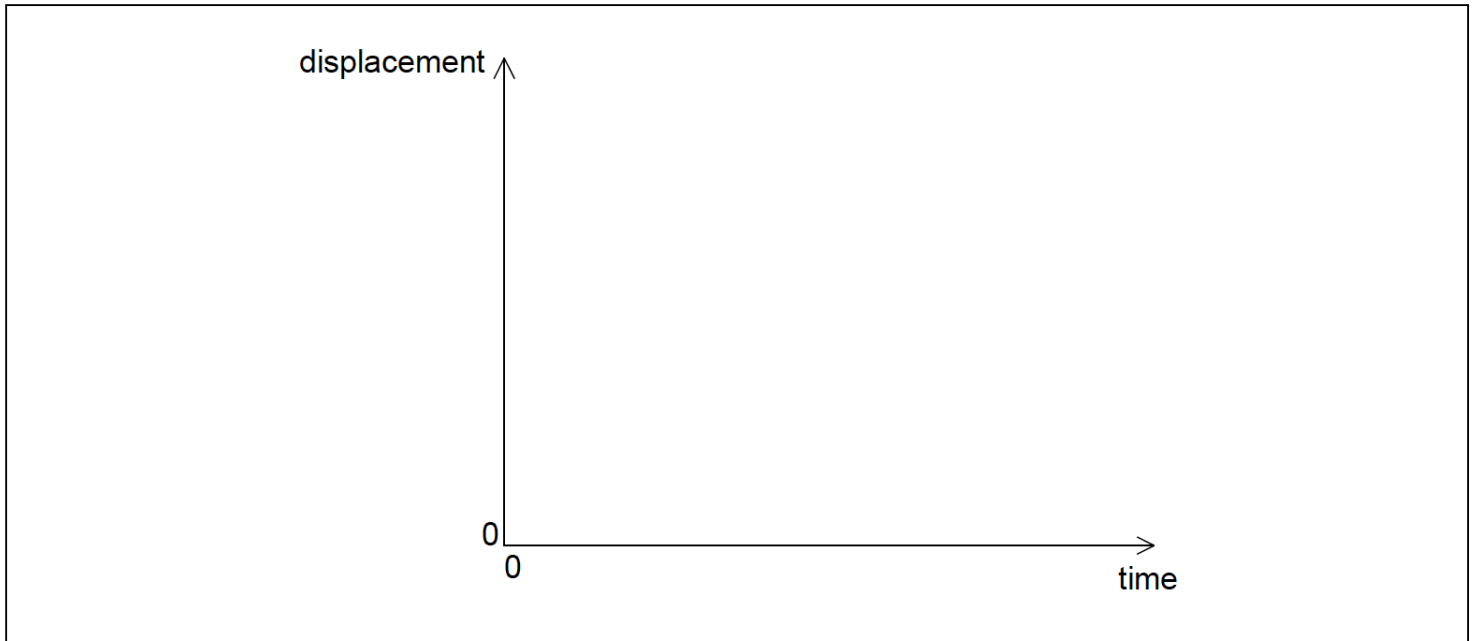

- d. The spring decompression takes 0.42s. Determine the average force that the spring exerts on the block. [2]

- e. The electric motor is connected to a source of potential difference 120V and draws a current of 6.8A. The motor takes 1.5s to compress the spring. [2]

Estimate the efficiency of the motor.

Markscheme

- a. (i)

$$\ll E_{el} = \gg \frac{1}{2}mv^2 + mgh$$

OR

$$\ll E_{el} = \gg E_P + E_K$$

$$\ll E_{el} = \gg \frac{1}{2} \times 55 \times 0.90^2 + 55 \times 9.8 \times 1.2$$

OR

669 J

$$\ll E_{el} = 669 \approx 670J \gg$$

Award [1 max] for use of $g=10Nkg^{-1}$, gives 682 J.

- (ii)

$$\frac{1}{2} \times 55 \times v^2 = 670J$$

$$v = \ll \sqrt{\frac{2 \times 670}{55}} = \gg 4.9ms^{-1}$$

If 682J used, answer is $5.0ms^{-1}$.

- b. (i)

no force/friction on the block, hence constant motion/velocity/speed

(ii)

force acts on block **OR** gravity/component of weight pulls down slope

velocity/speed decreases **OR** it is slowing down **OR** it decelerates

Do not allow a bald statement of “ N_2 ” or “ $F = ma$ ” for MP1.

Treat references to energy as neutral.

- c. straight line through origin for at least one-third of the total length of time axis **covered by candidate line**

followed by curve with decreasing positive gradient

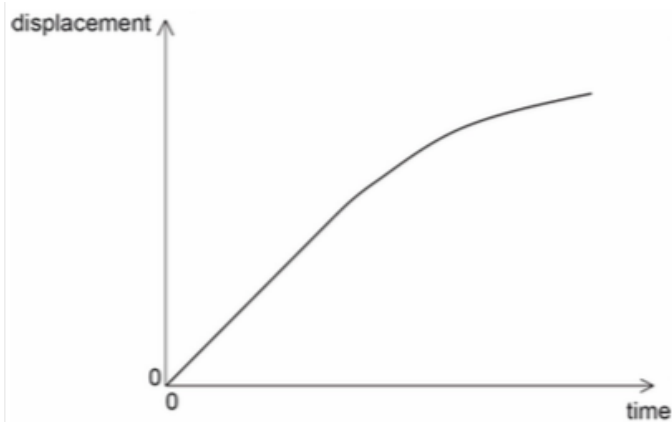

Ignore any attempt to include motion before A.

Gradient of curve must always be less than that of straight line.

d. $F \ll = \frac{\Delta p}{\Delta t} \gg = \frac{55 \times 4.9}{0.42}$

$$F = 642 \approx 640 \text{ N}$$

Allow ECF from (a)(ii).

- e. «energy supplied by motor \Rightarrow $120 \times 6.8 \times 1.5$ **or** 1224 J

OR

«power supplied by motor \Rightarrow 120×6.8 **or** 816 W

$$e = 0.55 \text{ or } 0.547 \text{ or } 55\% \text{ or } 54.7\%$$

Allow ECF from earlier results.

Examiners report

- a. [N/A]
- b. [N/A]
- c. [N/A]
- d. [N/A]
- e. [N/A]

This question is in **two** parts. **Part 1** is about power and efficiency. **Part 2** is about electrical resistance.

Part 1 Power and efficiency

A bus is travelling at a constant speed of 6.2 m s^{-1} along a section of road that is inclined at an angle of 6.0° to the horizontal.

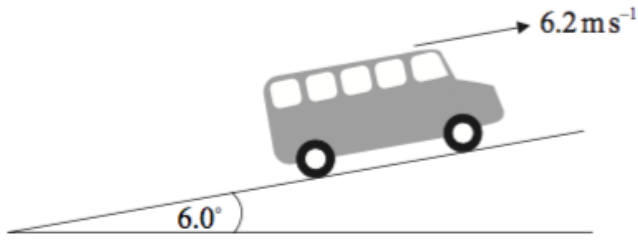

- a. (i) The bus is represented by the black dot shown below. Draw a labelled sketch to represent the forces acting on the bus.

[5]

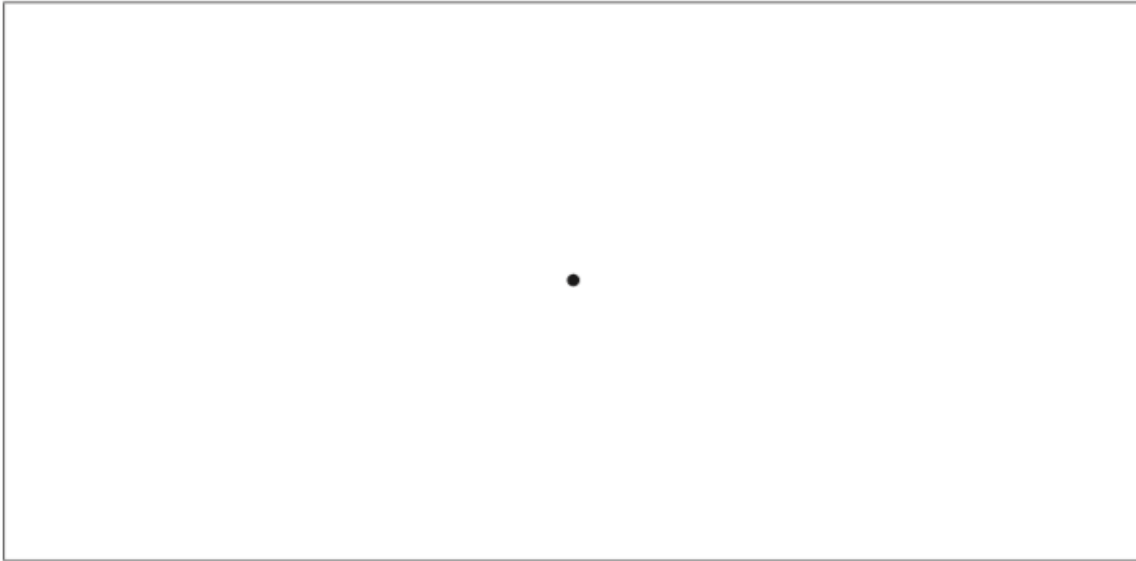

- (ii) State the value of the rate of change of momentum of the bus.
- b. The total output power of the engine of the bus is 70 kW and the efficiency of the engine is 35% . Calculate the input power to the engine. [2]
- c. The mass of the bus is $8.5 \times 10^3 \text{ kg}$. Determine the rate of increase of gravitational potential energy of the bus. [3]
- d. Using your answer to (c) and the data in (b), estimate the magnitude of the resistive forces acting on the bus. [3]
- e. The engine of the bus suddenly stops working. [4]
- (i) Determine the magnitude of the net force opposing the motion of the bus at the instant at which the engine stops.
- (ii) Discuss, with reference to the air resistance, the change in the net force as the bus slows down.

Markscheme

- a. (i)

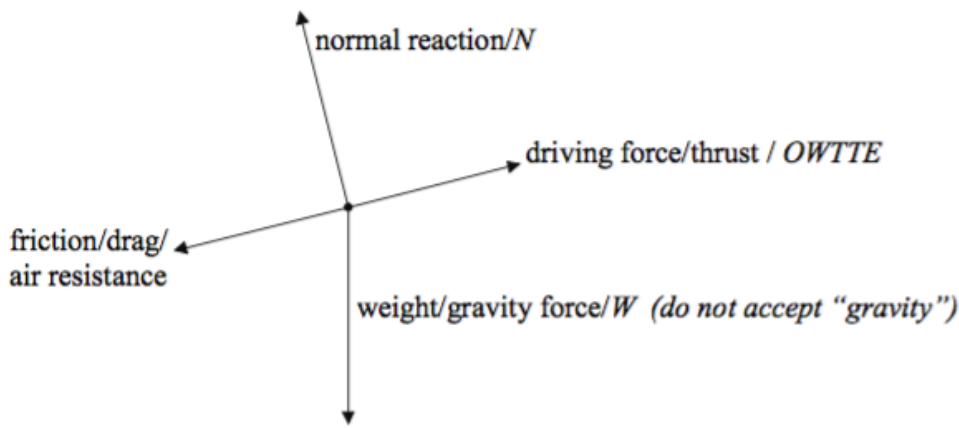

identification of normal reaction/ N and weight/ W ;

identification of friction and driving force;

correct directions of all four forces;

correct relative lengths; { (friction \approx driving force and $N \approx W$ but N must not be longer than W) (judge by eye)

(ii) zero;

b. input power = $\frac{\text{output power}}{\text{efficiency}} = \frac{70}{0.35}$;
 = 200 kW;

Award **[2]** for a bald correct answer.

c. height gained in 1s = $(6.2 \sin 6^\circ) = 0.648(\text{m})$;

rate of change of PE = $8.5 \times 10^3 \times 9.81 \times 0.648$;

= $5.4 \times 10^4 \text{W}$;

d. power used to overcome friction = $(7 \times 10^4 - 5.4 \times 10^4) = 1.6 \times 10^4 (\text{W})$; {(allow ECF from (c))}

$$F = \left(\frac{p}{v} \right) = \frac{1.6 \times 10^4}{6.2};$$

= 2.6 kN;

e. (i) component of weight down slope = $8.5 \times 10^3 \times 9.81 \sin 6^\circ$;

net force = $2.6 \times 10^3 + 8.5 \times 10^3 \times 9.81 \sin 6^\circ$

= 11 kN;

Watch for ECF from (d).

(ii) air resistance decreases as speed drops;

so net force decreases;

Examiners report

a. (i) Diagrams were poorly presented and ill-thought. 4 marks were assigned to this and candidates should have given much more care to it. Marks were given for appropriate descriptions, directions and lengths of the vectors. In particular, candidates should recognize that the term “acceleration” will not do for a driving force, and that “normal” simply implies “at 90°”. The essential point about the upwards force from the surface is that it is a reaction force.

(ii) About half the candidates realized that the momentum change was zero as the velocity was constant. The efficiency calculation was well done by many.

- b. This question produced a mixed response varying from excellent fully-explained solutions to incoherent attempts with an incompetent inclusion of components or attempts that focussed on the change in the kinetic energy.
- d. Many recognized that the way to estimate the forces was to access the net rate of change of energy and divide this by the speed, but there were two hurdles here: a determination of the correct net power and the correct speed. Very many failed at one or both of these and thus failed to provide a correct answer.
- e.

This question is about forces.

A stone block is pulled at constant speed up an incline by a cable attached to an electric motor.

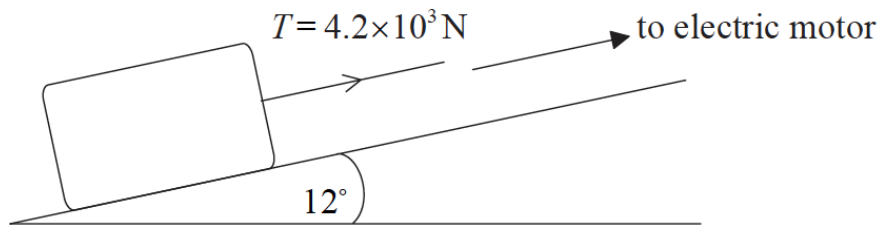

The incline makes an angle of 12° with the horizontal. The weight of the block is $1.5 \times 10^4 \text{ N}$ and the tension T in the cable is $4.2 \times 10^3 \text{ N}$.

- a. On the diagram draw and label arrows that represent the forces acting on the block. [2]
- b. Calculate the magnitude of the friction force acting on the block. [3]

Markscheme

a.

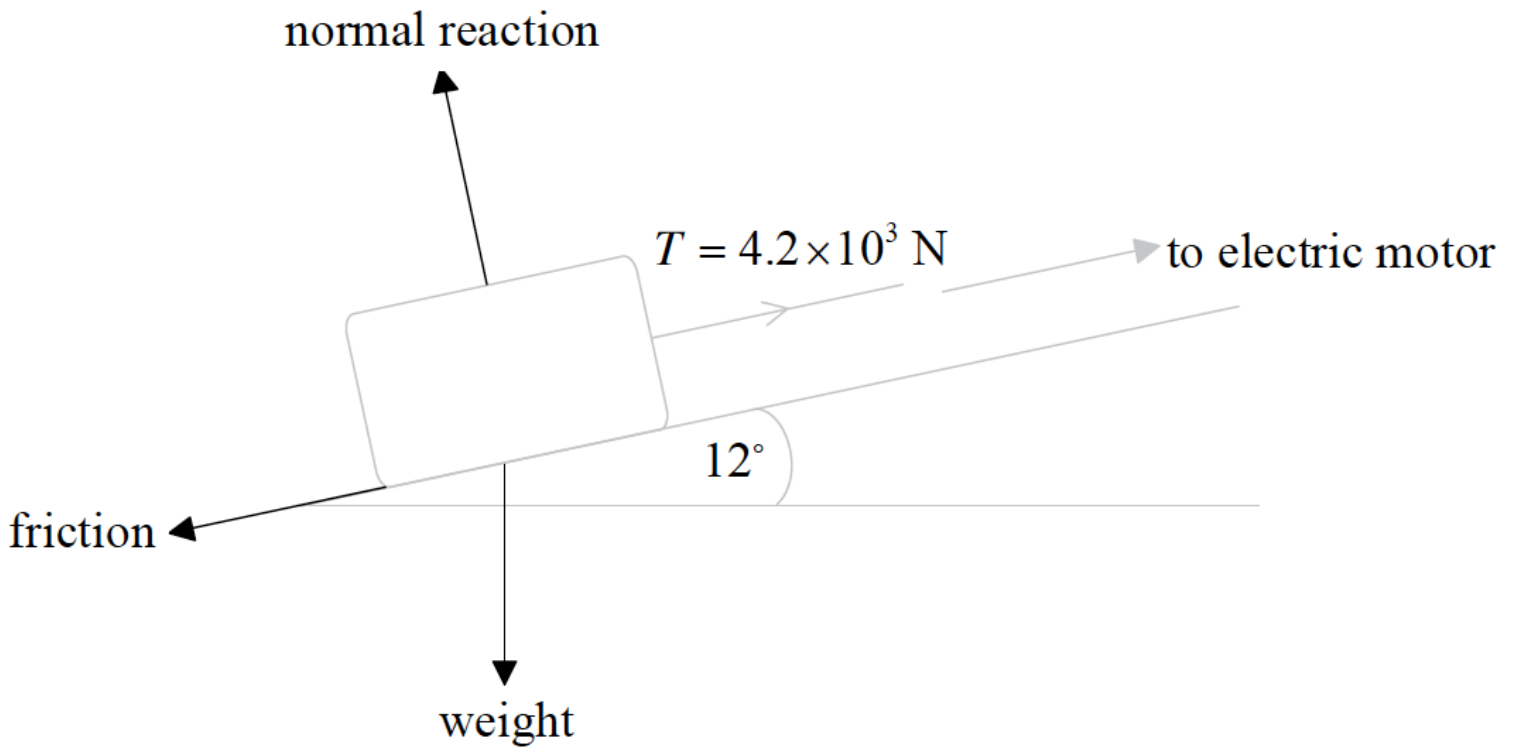

(normal) reaction/ N/R and weight/force of gravity/gravity force/gravitational force/ $mg/w/W$ with correct directions;
friction/frictional force/ F/F_f with arrow pointing down ramp along surface of ramp;
Do not allow "gravity" as label. Do not allow "drag" as label for friction.

b. recognize that friction= $T-W \sin \theta$;

$$W \sin \theta = 3.1 \times 10^3 \text{ N};$$

$$\text{friction} = 1.1 \times 10^3 \text{ N};$$

Examiners report

a. [N/A]

b. [N/A]

This question is in two parts. **Part 1** is about forces. **Part 2** is about internal energy.

Part 1 Forces

A railway engine is travelling along a horizontal track at a constant velocity.

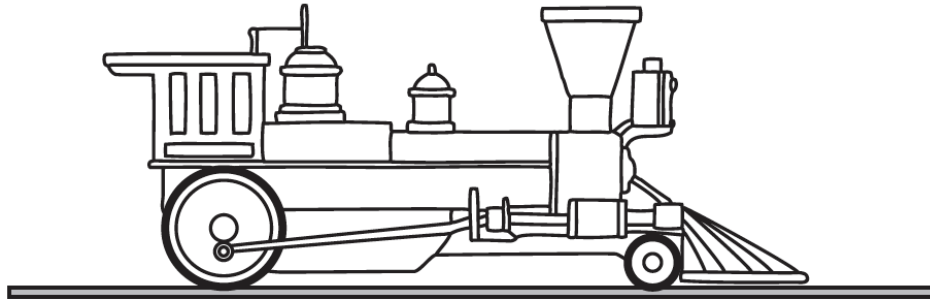

- a. On the diagram above, draw labelled arrows to represent the vertical forces that act on the railway engine. [3]
- b. Explain, with reference to Newton's laws of motion, why the velocity of the railway engine is constant. [2]
- c. The constant horizontal velocity of the railway engine is 16 ms^{-1} . A total horizontal resistive force of 76 kN acts on the railway engine. [2]
Calculate the useful power output of the railway engine.
- d. The power driving the railway engine is switched off. The railway engine stops, from its speed of 16 ms^{-1} , without braking in a distance of 1.1 km . A student hypothesizes that the horizontal resistive force is constant. [2]
Based on this hypothesis, calculate the mass of the railway engine.
- e. Another hypothesis is that the horizontal force in (c) consists of two components. One component is a constant frictional force of 19 kN . The other component is a resistive force F that varies with speed v where F is proportional to v^3 . [5]
(i) State the value of the magnitude of F when the railway engine is travelling at 16 ms^{-1} .
(ii) Determine the **total** horizontal resistive force when the railway engine is travelling at 8.0 ms^{-1} .
- f. On its journey, the railway engine now travels around a curved track at constant speed. Explain whether or not the railway engine is accelerating. [3]

Markscheme

a.

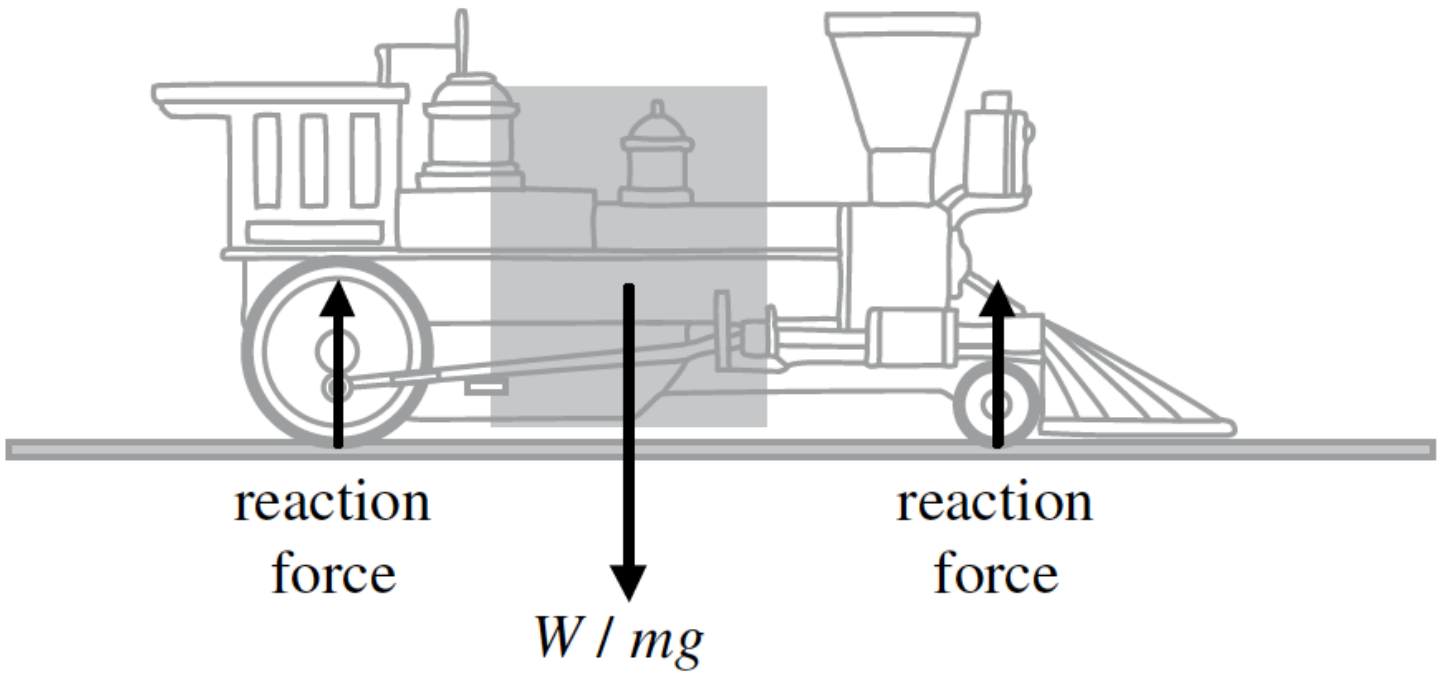

The shaded box shows the acceptable range of position for W/mg .

single downward arrow labelled W /weight **or** mg /gravity force; (do not allow gravity)

two upward arrows labelled reaction/contact forces; (do not allow for only one arrow seen)

arrow positions as shown in diagram;

b. horizontal forces have resultant of zero; (must describe or imply horizontal force)

valid statement linked to theory (e.g. Newton 1/Newton 2/conservation of momentum)

explaining why zero force results in constant velocity/zero acceleration;

c. power = 16×76000 ;

1.2 MW;

d. acceleration = $\frac{16^2}{2 \times 1100}$ (= 0.116);

$$m = \left(\frac{7.6 \times 10^4}{0.116} \right) = 6.5 \times 10^5 \text{ kg};$$

Award [2] for a bald correct answer.

or

use of $Fs = \frac{1}{2}mv^2$;

$$m = \left(\frac{2 \times 7.6 \times 10^4 \times 1100}{16^2} \right) = 6.5 \times 10^5 \text{ kg};$$

Award [2] for a bald correct answer.

e. (i) 57 kN;

$$\text{(ii) } F_8 = \frac{F_{16}}{2^3};$$

$$F_8 = 7.1 \text{ (kN)};$$

$$\text{total force} = 19 + 7.1 \text{ (kN)};$$

$$= 26 \text{ kN};$$

Award [4] for a bald correct answer.

or

$$k = \left(\frac{57 \times 10^3}{16^3} \right) = 13.91;$$

$$F_8 = (13.91 \times 8^3) = 7.1 \text{ (kN)};$$

$$\text{total force} = 19 + 7.1 \text{ (kN)};$$

=26 kN;

Award [4] for a bald correct answer.

f. direction of engine is constantly changing;

velocity is speed + direction / velocity is a vector;

engine is accelerating as velocity is changing;

Award [0] for a bald correct answer.

or

centripetal force required to maintain circular motion;

quotes Newton 1/Newton 2;

so engine is accelerating as a force acts;

Award [0] for a bald correct answer.

Examiners report

- a. [N/A]
- b. [N/A]
- c. [N/A]
- d. [N/A]
- e. [N/A]
- f. [N/A]

Impulse and momentum

The diagram shows an arrangement used to test golf club heads.

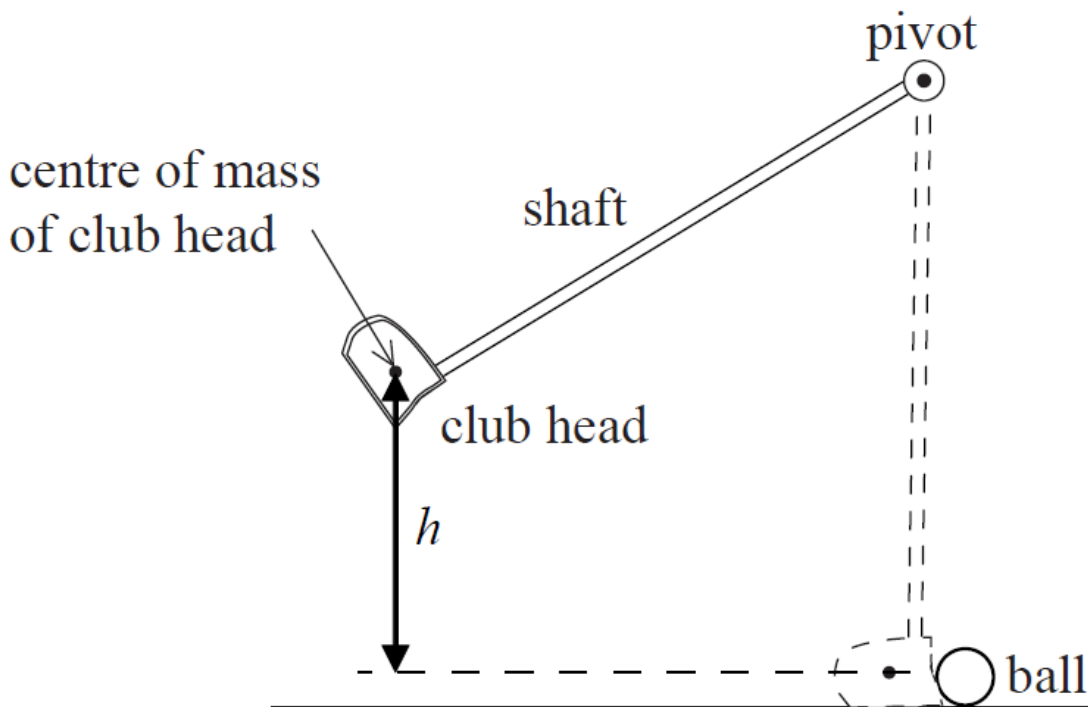

The shaft of a club is pivoted and the centre of mass of the club head is raised by a height h before being released. On reaching the vertical position the club head strikes the ball.

a. (i) Describe the energy changes that take place in the club head from the instant the club is released until the club head and the ball separate. [4]

(ii) Calculate the maximum speed of the club head achievable when $h = 0.85$ m.

b. The diagram shows the deformation of a golf ball and club head as they collide during a test. [2]

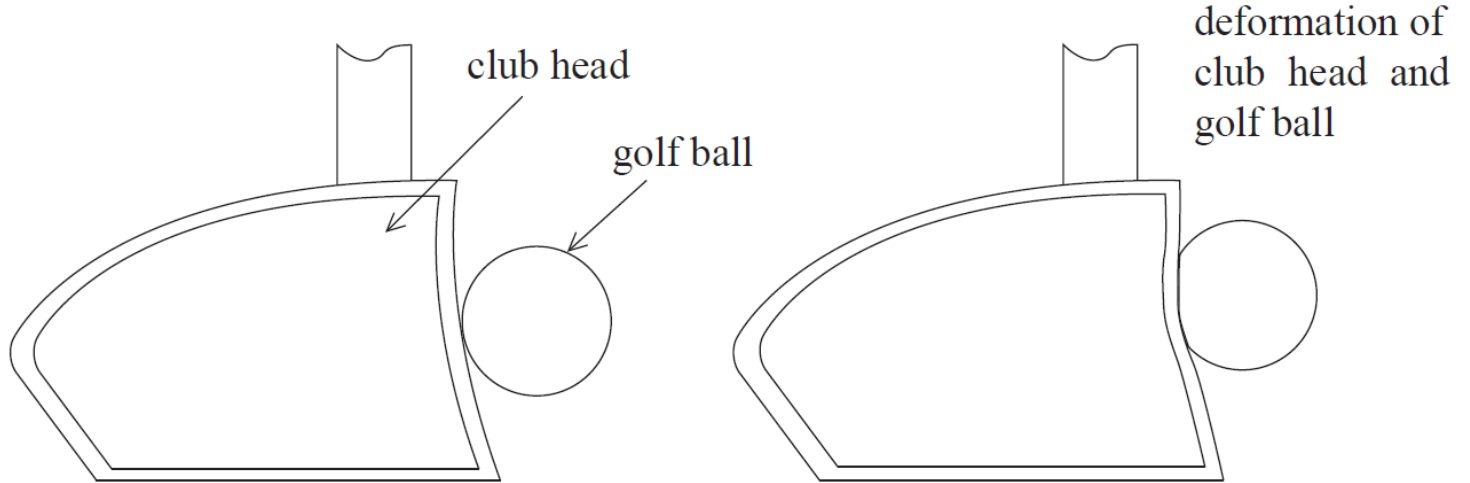

Explain how increasing the deformation of the club head may be expected to increase the speed at which the ball leaves the club.

c. In a different experimental arrangement, the club head is in contact with the ball for a time of $220 \mu\text{s}$. The club head has mass 0.17 kg and the ball has mass 0.045 kg. At the moment of contact the ball is at rest and the club head is moving with a speed of 38 ms^{-1} . The ball moves off with an initial speed of 63 ms^{-1} . [5]

(i) Calculate the average force acting on the ball while the club head is in contact with the ball.

(ii) State the average force acting on the club head while it is in contact with the ball.

(iii) Calculate the speed of the club head at the instant that it loses contact with the ball.

Markscheme

a. (i) (gravitational) potential energy (of club head) goes to kinetic energy (of club head);

some kinetic energy of club head goes to internal energy of club head/kinetic energy of ball;

(ii) equating mgh to $\frac{1}{2}mv^2$;

$v=4.1(\text{ms}^{-1})$;

Award [0] for answers using equation of motion – not uniform acceleration.

b. deformation prolongs the contact time;

increased impulse => bigger change of momentum/velocity;

or

(club head) stores (elastic) potential energy on compression;

this energy is passed to the ball;

c. (i) any value of $\frac{\text{mass} \times \text{velocity}}{\text{time}}$;

1.3×10^4 (N);

(ii) -1.3×10^4 (N);

Accept statement that force is in the opposite direction to (c)(i).

Allow the negative of any value given in (c)(i).

(iii) clear use of conservation of momentum / impulse = change of momentum;

21(ms⁻¹);

or

$$a = \left(\frac{F}{m} = \frac{-13000}{0.17} = \right) (-) 76500 \text{ (ms}^{-1}\text{)};$$

$$v = (u + at = 38 - 76500 \times 0.00022 =) 21 \text{ (ms}^{-1}\text{)};$$

Award [2] for a bald correct answer.

Examiners report

- a. (i) Nearly all candidates gained a mark for recognising the change from kinetic to potential energy in this part. Fewer recognised that the club head would not transfer all of its energy to the ball and therefore retained a significant amount of energy.
- (ii) This part was well done by many.
- b. A minority of candidates became bogged down by the deformation of the ball and club head idea and ventured into elastic potential energy ideas. This had a successful outcome in many cases when there was discussion of the compression providing further kinetic energy to the ball on recovering its shape. The most straightforward solution was to use the principle of impulse being equal to the change in momentum (as shown in the question heading) and simply to recognise that an increased contact time would be expected to give a greater change of momentum for a constant force.
- c. (i) This was well done with the only real problem being deciding which was the speed change of the ball.
- (ii) Less candidates than anticipated recognised that the force on the club head was equal and opposite to that acting on the ball (applying Newton's third law of motion).
- (iii) Most made a good attempt at calculating the speed of the club head.

This question is in two parts. **Part 1** is about momentum. **Part 2** is about electric point charges.

Part 1 Momentum

Part 2 Electric point charges

- a. State the law of conservation of linear momentum. [2]
- b. A toy car crashes into a wall and rebounds at right angles to the wall, as shown in the plan view. [9]

before the crash



after the crash

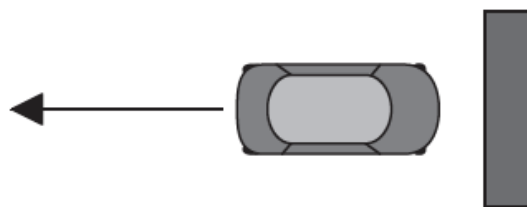

The graph shows the variation with time of the force acting on the car due to the wall during the collision.

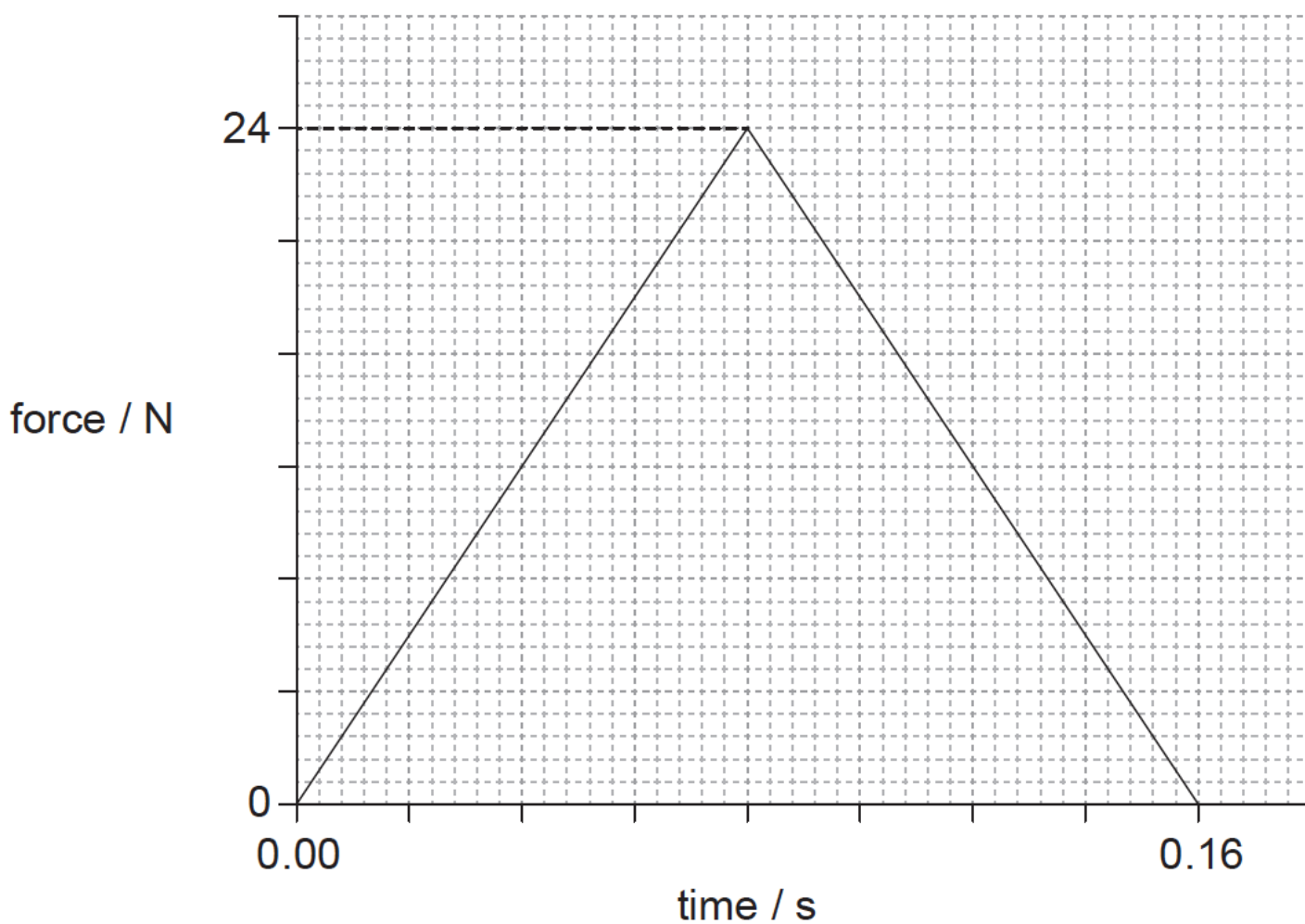

The kinetic energy of the car is unchanged after the collision. The mass of the car is 0.80 kg.

- Determine the initial momentum of the car.
- Estimate the average acceleration of the car before it rebounds.
- On the axes, draw a graph to show how the momentum of the car varies during the impact. You are not required to give values on the y-axis.

momentum



- c. Two identical toy cars, A and B are dropped from the same height onto a solid floor without rebounding. Car A is unprotected whilst car B is in a box with protective packaging around the toy. Explain why car B is less likely to be damaged when dropped. [4]
- d. Define *electric field strength* at a point in an electric field. [2]
- e. Six point charges of equal magnitude Q are held at the corners of a hexagon with the signs of the charges as shown. Each side of the hexagon has a length a . [8]

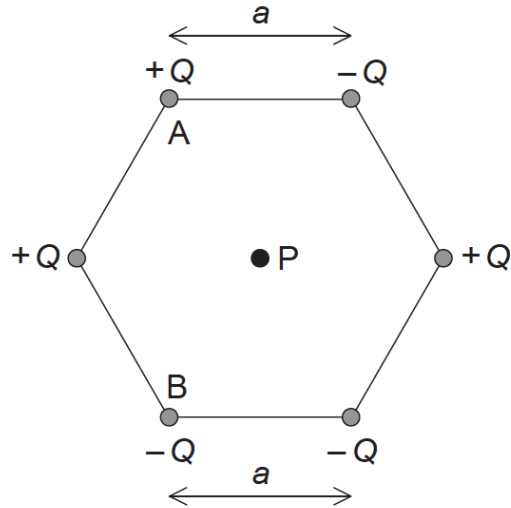

P is at the centre of the hexagon.

(i) Show, using Coulomb's law, that the magnitude of the electric field strength at point P due to **one** of the point charges is

$$\frac{kQ}{a^2}$$

(ii) On the diagram, draw arrows to represent the direction of the field at P due to point charge A (label this direction A) and point charge B (label this direction B).

(iii) The magnitude of Q is $3.2 \mu\text{C}$ and length a is 0.15 m. Determine the magnitude and the direction of the electric field strength at point P due to all six charges.

Markscheme

a. total momentum does not change/is constant; } (do not allow "momentum is conserved")

provided external force is zero / no external forces / isolated system;

b. (i) clear attempt to calculate area under graph;

initial momentum is half change in momentum;

$$\left(\frac{1}{2} \times \frac{1}{2} \times 24 \times 0.16\right) = 0.96 \text{ (kgms}^{-1}\text{)}$$

Award **[2 max]** for calculation of total change (1.92kg ms^{-1})

$$\text{(ii) initial speed} = \left(\frac{0.96}{0.8}\right) = 1.2\text{ms}^{-1};$$

$$a = \frac{1.2 - (-1.2)}{0.16} \text{ or } a = \frac{-1.2 - 1.2}{0.16};$$

$-15(\text{ms}^{-2})$; (must see negative sign or a comment that this is a deceleration)

or

average force = 12 N;

uses $F = 0.8 \times a$;

$-15(\text{ms}^{-2})$; (must see negative sign or a comment that this is a deceleration)

Award **[3]** for a bald correct answer.

Other solution methods involving different kinematic equations are possible.

(iii) goes through $t=0.08\text{s}$ **and** from negative momentum to positive / positive momentum to negative;

constant sign of gradient throughout;

curve as shown;

Award marks for diagram as shown.

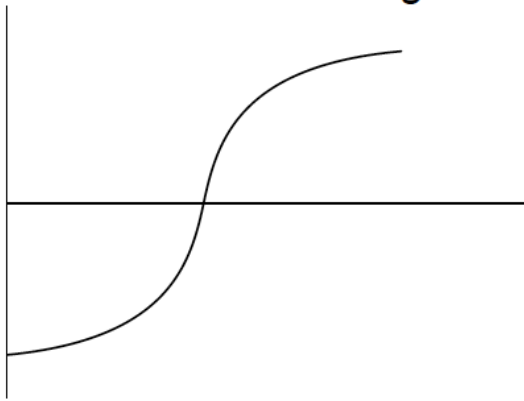

or

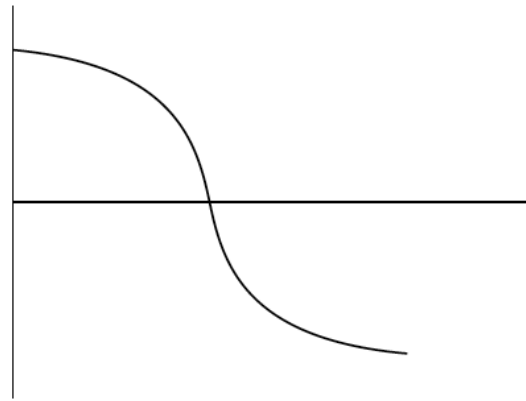

c. impulse is the same/similar in both cases / momentum change is same;

impulse is force \times time / force is rate of change of momentum;

time to come to rest is longer for car B;

force experienced by car B is less (so less likely to be damaged);

d. electric force per unit charge;

acting on a small/point positive (test) charge;

e. (i) states Coulomb's law as $\frac{kQq}{r^2}$ **or** $\frac{F}{q} = \frac{kQ}{r^2}$

states explicitly $q=1$;

states $r=a$;

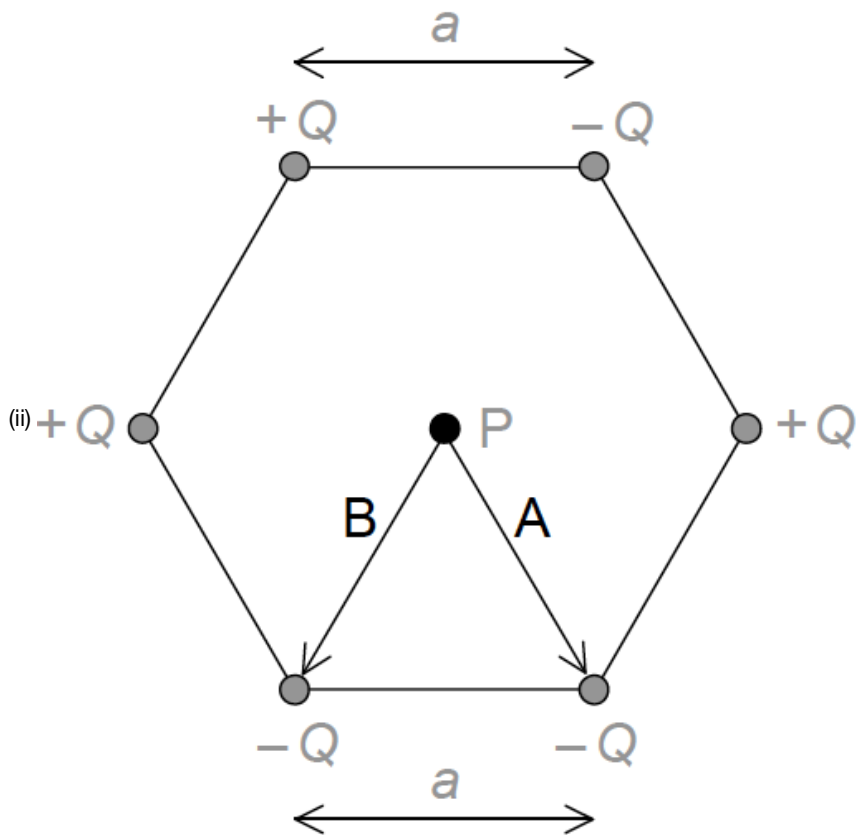

arrow labelled A pointing to lower right charge;

arrow labelled B point to lower left charge;

Arrows can be anywhere on diagram.

(iii) overall force is due to $+Q$ top left and $-Q$ bottom right / top right and bottom left and centre charges all cancel; } (can be seen on diagram)

force is therefore $\frac{2kQ}{a^2}$;

2.6×10^6 (N C⁻¹);

towards bottom right charge; (allow clear arrow on diagram showing direction)

Examiners report

- a. [N/A]
- b. [N/A]
- c. [N/A]
- d. [N/A]
- e. [N/A]

This question is in **two** parts. **Part 1** is about two children on a merry-go-round. **Part 2** is about electric circuits.

Part 1 Two children on a merry-go-round

Aibhe and Euan are sitting on opposite sides of a merry-go-round, which is rotating at constant speed around a fixed centre. The diagram below shows the view from above.

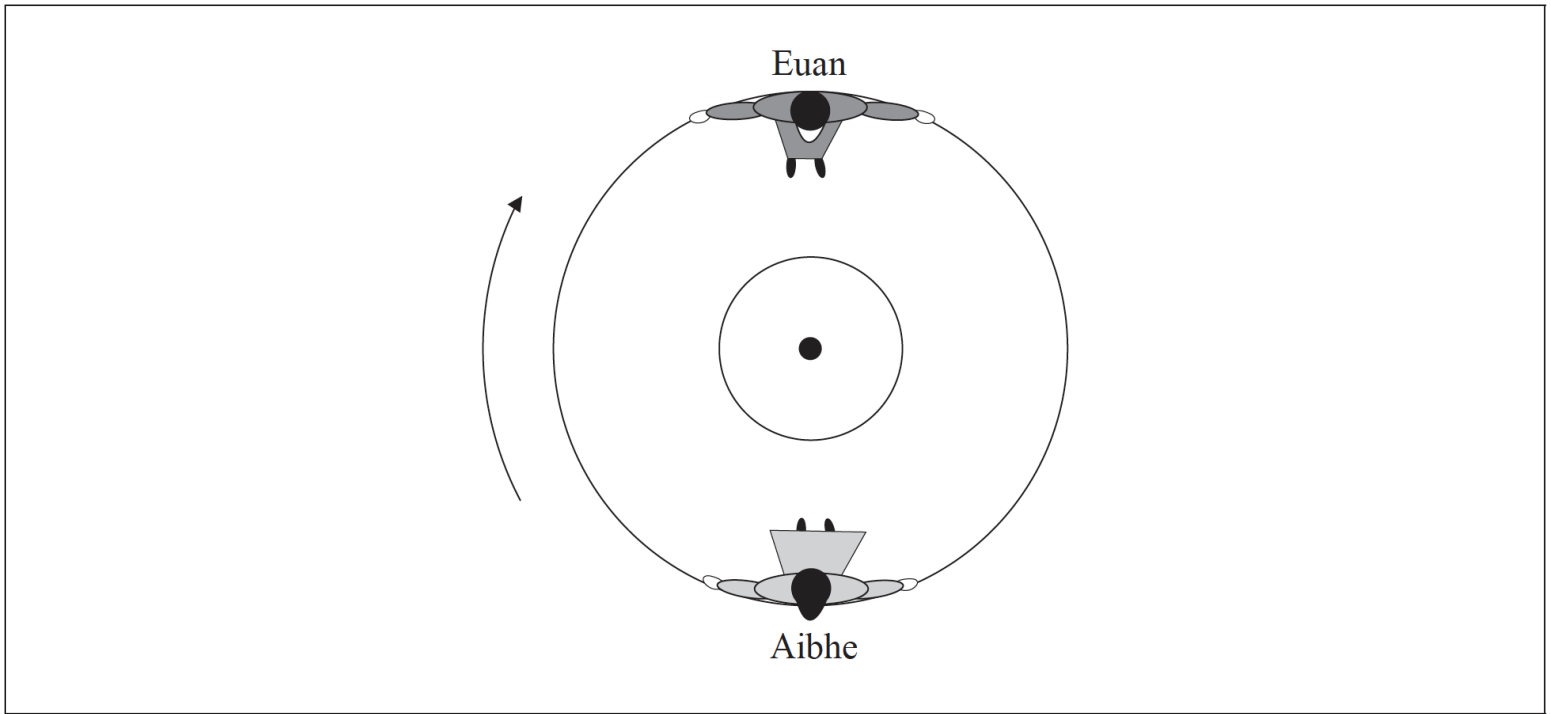

Aibhe is moving at speed 1.0ms^{-1} relative to the ground.

Part 2 Orbital motion

A spaceship of mass m is moving at speed v in a circular orbit of radius r around a planet of mass M .

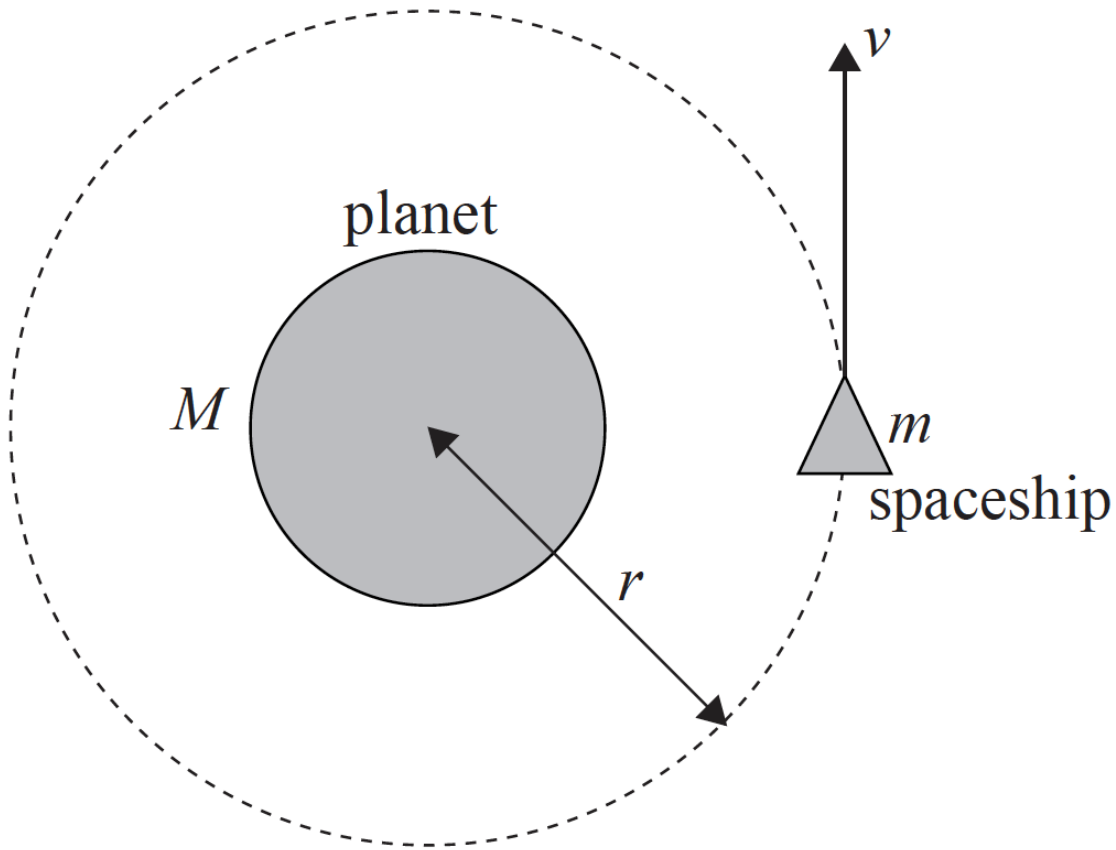

(not to scale)

a. Determine the magnitude of the velocity of Aibhe relative to

- (i) Euan.
- (ii) the centre of the merry-go-round.

b. (i) Outline why Aibhe is accelerating even though she is moving at constant speed.

[6]

- (ii) Draw an arrow on the diagram on page 22 to show the direction in which Aibhe is accelerating.
- (iii) Identify the force that is causing Aibhe to move in a circle.
- (iv) The diagram below shows a side view of Aibhe and Euan on the merry-go-round.

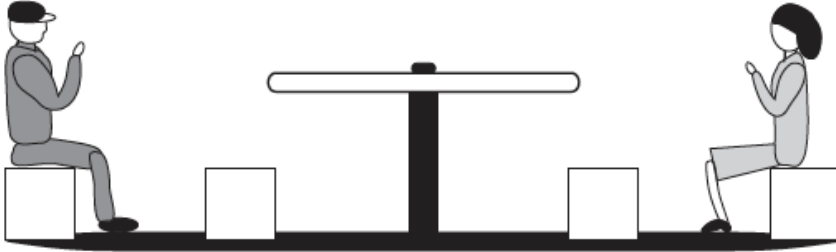

Explain why Aibhe feels as if her upper body is being “thrown outwards”, away from the centre of the merry-go-round.

c. Euan is rotating on a merry-go-round and drags his foot along the ground to act as a brake. The merry-go-round comes to a stop after 4.0 rotations. The radius of the merry-go-round is 1.5 m. The average frictional force between his foot and the ground is 45 N. Calculate the work done.

[2]

d. Aibhe moves so that she is sitting at a distance of 0.75 m from the centre of the merry-go-round, as shown below.

[5]

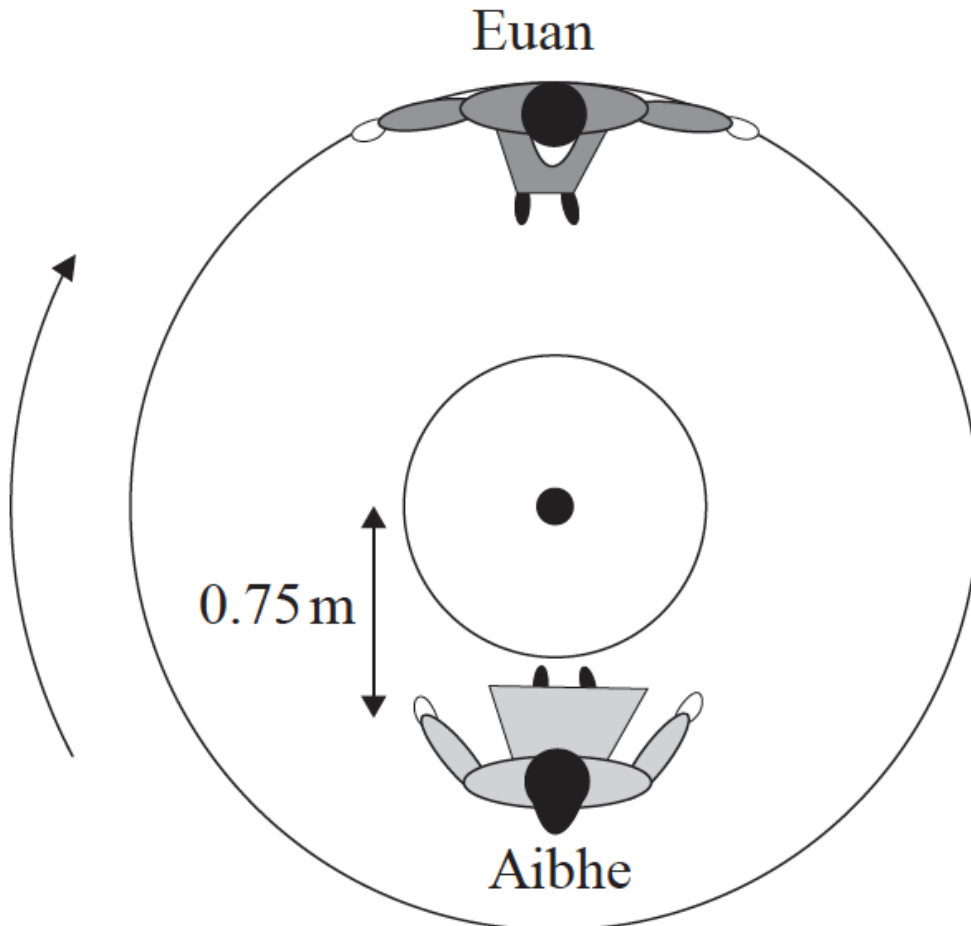

Euan pushes the merry-go-round so that he is again moving at 1.0 ms^{-1} relative to the ground.

- (i) Determine Aibhe’s speed relative to the ground.

(ii) Calculate the magnitude of Aibhe's acceleration.

e. Define the *electric resistance* of a wire. [1]

f. Using the following data, calculate the length of constantan wire required to make a resistor with a resistance of 6.0Ω . [3]

Resistivity of constantan = $5.0 \times 10^{-7} \Omega\text{m}$

Average radius of wire = $2.5 \times 10^{-5} \text{m}$

g. Three resistors, each of resistance 6.0Ω , are arranged in the circuit shown below. The cell has an emf of 12V and negligible internal resistance. [3]

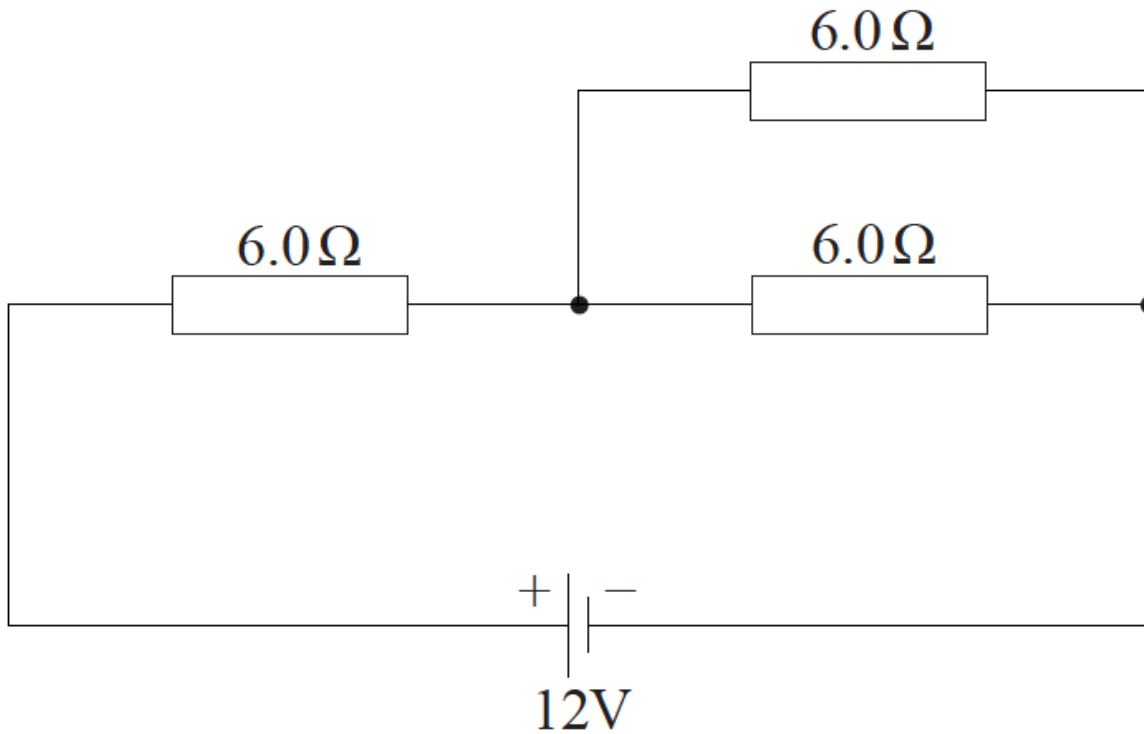

Determine the total power supplied by the cell.

h. The same resistors and cell are now re-arranged into a different circuit, as shown below. [3]

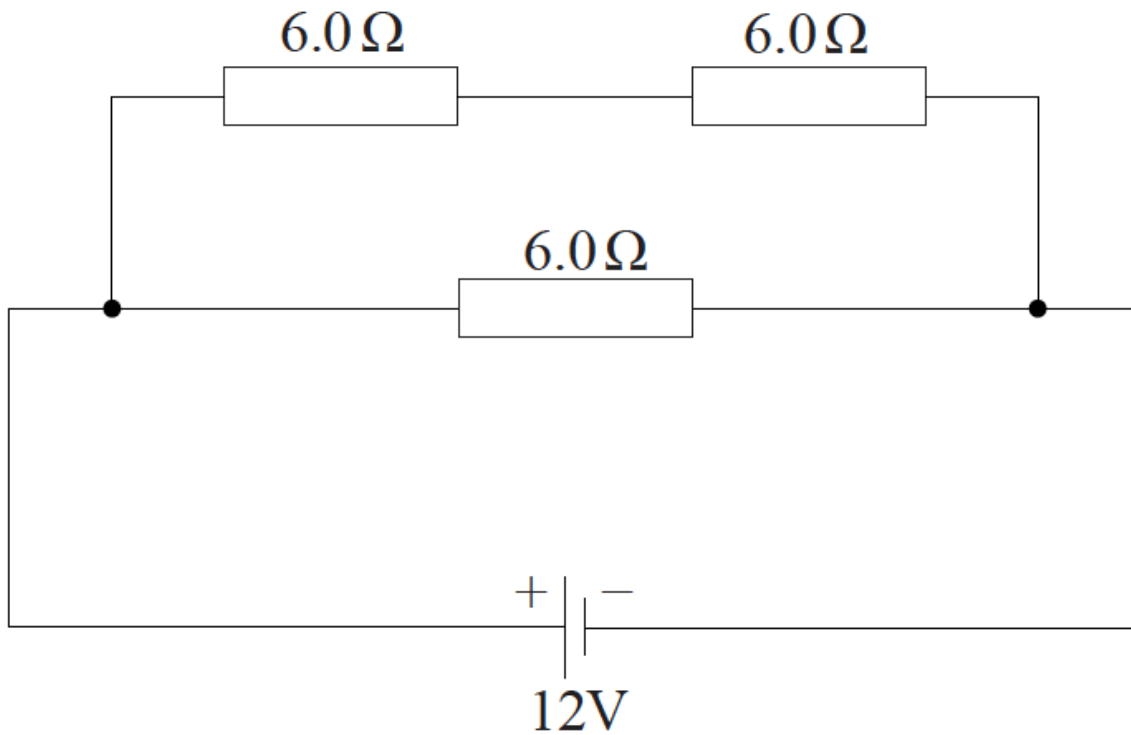

Explain why the total power supplied by the cell is greater than for the circuit in (g).

Markscheme

- a. (i) 2.0 **or** 0(ms^{-1});
 (ii) 1.0 **or** 0(ms^{-1});
- b. (i) her direction is changing;
 hence her velocity is changing;
or
 since her direction/velocity is changing;
 a resultant/unbalanced/net force must be acting on her (hence she is accelerating);
- (ii) arrow from Aibhe towards centre of merry-go-round;
Ignore length of arrow.
- (iii) the force of the merry-go-round on Aibhe/her;
- (iv) no force is acting on the upper body towards the centre of the circle / no centripetal force acting on the upper body (to maintain circular motion);
 upper body (initially) continues to move in a straight line at constant speed/ velocity is tangential to circle;
 distance travelled by Euan = $4.0 \times 2\pi \times 1.5 (= 37.70\text{m})$;
- c. $W (= F_{av}d = 45 \times 37.70) = 1700 (\text{J})$;
- d. (i) Aibhe's period of revolution is the same as before;
 from $v = \frac{2\pi r}{T}$, since r is halved, v is halved;
 $v = 0.5(\text{ms}^{-1})$;
Award [3] for a bald correct answer.
- (ii) $a \left(= \frac{v^2}{r} \right) = \frac{0.5^2}{0.75}$;
 $a = 0.33(\text{ms}^{-2})$;
Allow ECF from (d)(i).
Award [2] for a bald correct answer.
- e. $\frac{\text{potential difference across the wire}}{\text{current through the wire}}$;
Accept equation with symbols defined. Accept p.d. Do not accept voltage.

$$f. A = (\pi r^2) \pi \times [2.5 \times 10^{-5}]^2 (= 1.963 \times 10^{-9});$$

$$l = \left(\frac{RA}{\rho} = \right) \frac{6.0 \times 1.963 \times 10^{-9}}{5.0 \times 10^{-7}};$$

$$= 2.4 \times 10^{-2} (\text{m});$$

Award [3] for a bald correct answer.

g. resistance of two resistors in parallel = $3.0(\Omega)$, so total resistance = $6.0 + 3.0 = 9.0(\Omega)$;

$$I = \left(\frac{V}{R} = \right) \frac{12}{9.0} (= 1.333) (\text{A});$$

$$P = (VI = 12 \times 1.333 =) 16 (\text{W});$$

or

resistance of two resistors in parallel = $3.0(\Omega)$, so total resistance = $6.0 + 3.0 = 9.0(\Omega)$;

$$P = \left(\frac{V^2}{R} = \right) \frac{144}{9.0};$$

$$P = 16 (\text{W});$$

h. total resistance is smaller ($=4.0\Omega$);

p.d./voltage is the same so current is greater ($=3.0\text{A}$);

since $P=VI$ or $P=I^2R$, power is greater ($=36\text{W}$);

or

total resistance is smaller ($= 4.0\Omega$); p.d./voltage is the same;

since $P=\frac{V^2}{R}$, power is greater ($=36\text{W}$);

Award [1] for a bald calculation of 36 (W). The marks are for an explanation.

Examiners report

a. Most were able to identify the relative speeds. The markscheme was amended to also include answers in terms of velocity.

b. i) This was well-answered with most identifying a change in direction and a change in velocity.

ii) The majority were able to show the direction of the centripetal acceleration.

iii) Few identified a force that would act on Aibhe. They did not realize that the centripetal force is the resultant of the forces acting.

iv) Few realized from the diagram that it would be difficult provide an inward directed force on Aibhe's upper torso. The consequence of this is that it would tend to continue to move in a direction which is tangential to the circle.

c. This was well done by many.

d. i) Many scored three marks here.

ii) Most candidates were able to gain both marks.

e. The definition of resistance was poorly attempted with many describing some difficulty that a current has in travelling down a wire.

f. This calculation was generally well done although it was disappointing to see a significant proportion of candidates who did not know the formula for the area of a circle.

g. Most were able to calculate the equivalent resistance of the combination of resistors and progress successfully to find the power supplied by the cell.

- h. Many recalculated the power but didn't provide an explanation and so consequently only scored one mark. Explanations were often detailed enough to score full marks.

This question is in **two** parts. **Part 1** is about kinematics and gravitation. **Part 2** is about radioactivity.

Part 1 Kinematics and gravitation

A ball is released near the surface of the Moon at time $t=0$. The point of release is on a straight line between the centre of Earth and the centre of the Moon. The graph below shows the variation with time t of the displacement s of the ball from the point of release.

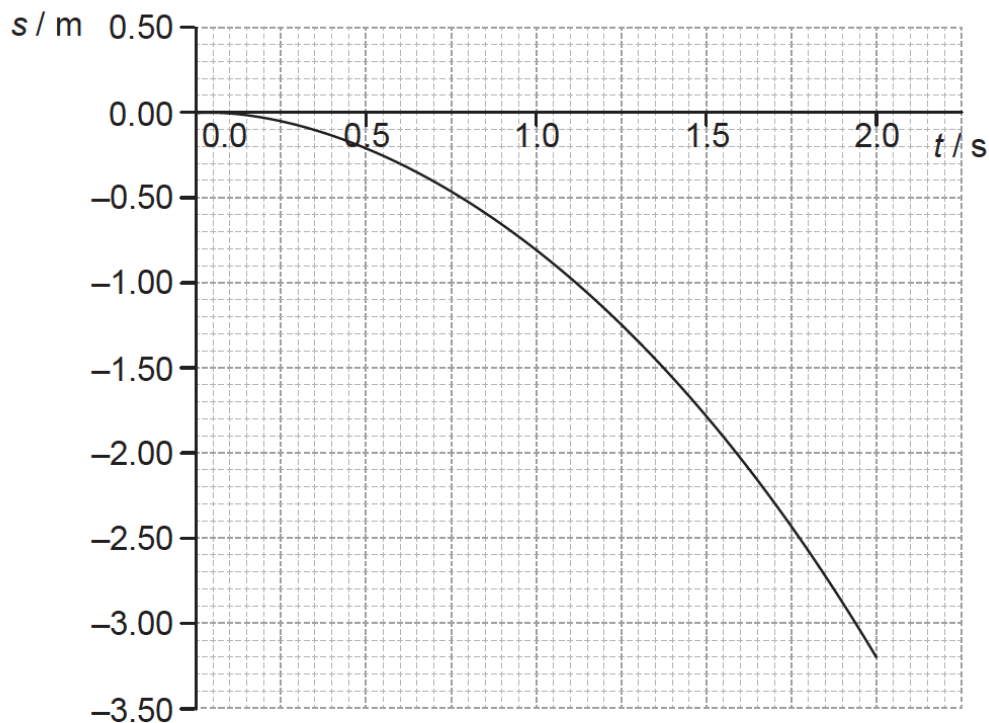

Part 2 Radioactivity

Two isotopes of calcium are calcium-40 (${}^{40}_{20}\text{Ca}$) and calcium-47 (${}^{47}_{20}\text{Ca}$). Calcium-40 is stable and calcium-47 is radioactive with a half-life of 4.5 days.

- a. State the significance of the negative values of s . [1]
- b. Use the graph to [6]
- estimate the velocity of the ball at $t = 0.80$ s.
 - calculate a value for the acceleration of free fall close to the surface of the Moon.
- c. The following data are available. [4]
- Mass of the ball = 0.20 kg
- Mean radius of the Moon = 1.74×10^6 m
- Mean orbital radius of the Moon about the centre of Earth = 3.84×10^8 m

Mass of Earth = 5.97×10^{24} kg

Show that Earth has no significant effect on the acceleration of the ball.

- d. Calculate the speed of an identical ball when it falls 3.0 m from rest close to the surface of Earth. Ignore air resistance. [1]
- e. Sketch, on the graph, the variation with time t of the displacement s from the point of release of the ball when the ball is dropped close to the surface of Earth. (For this sketch take the direction towards the Earth as being negative.) [3]
- f. Explain, in terms of the number of nucleons and the forces between them, why calcium-40 is stable and calcium-47 is radioactive. [3]
- g. Calculate the percentage of a sample of calcium-47 that decays in 27 days. [3]
- h. The nuclear equation for the decay of calcium-47 into scandium-47 (${}_{21}^{47}\text{Sc}$) is given by [4]

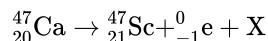

(i) Identify X.

(ii) The following data are available.

Mass of calcium-47 nucleus = 46.95455 u

Mass of scandium-47 nucleus = 46.95241 u

Using the data, determine the maximum kinetic energy, in MeV, of the products in the decay of calcium-47.

(iii) State why the kinetic energy will be less than your value in (h)(ii).

Markscheme

- a. upwards (or away from the Moon) is taken as positive / downwards (or towards the Moon) is taken as negative / towards the Earth is positive;
- b. (i) tangent drawn to curve at 0.80s;
correct calculation of gradient of tangent drawn;
 $-1.3 \pm 0.1 \text{ m s}^{-1}$ **or** $1.3 \pm 0.1 \text{ m s}^{-1}$ downwards;
or
correct coordinates used from the graph; substitution into a correct equation;
 $-1.3 \pm 0.1 \text{ m s}^{-1}$ **or** $1.3 \pm 0.1 \text{ m s}^{-1}$ downwards;
- (ii) any correct method used;
correct reading from graph;
 1.6 to 1.7 m s^{-2} ;
- c. values for masses, distance and correct G substituted into Newton's law;
see subtraction (*ie* r value = $3.84 \times 10^8 - 1.74 \times 10^6 = 3.82 \times 10^8 \text{ m}$);
 $F = 5.4$ to $5.5 \times 10^{-4} \text{ N}$ / $a = 2.7 \times 10^{-3} \text{ m s}^{-2}$;
comment that it's insignificant compared with ($0.2 \times 1.63 =$) 0.32 to 0.33 N / 1.63 m s^{-2} ;
- d. 7.7 m s^{-1} ;
- e. curve permanently below Moon curve;
smooth parabola; (*judge by eye*)

line passing through $s = -3.00$ m, $t = 0.78$ s **or** $s = -3.50$ m, $t = 0.84$ s (± 1 mm);

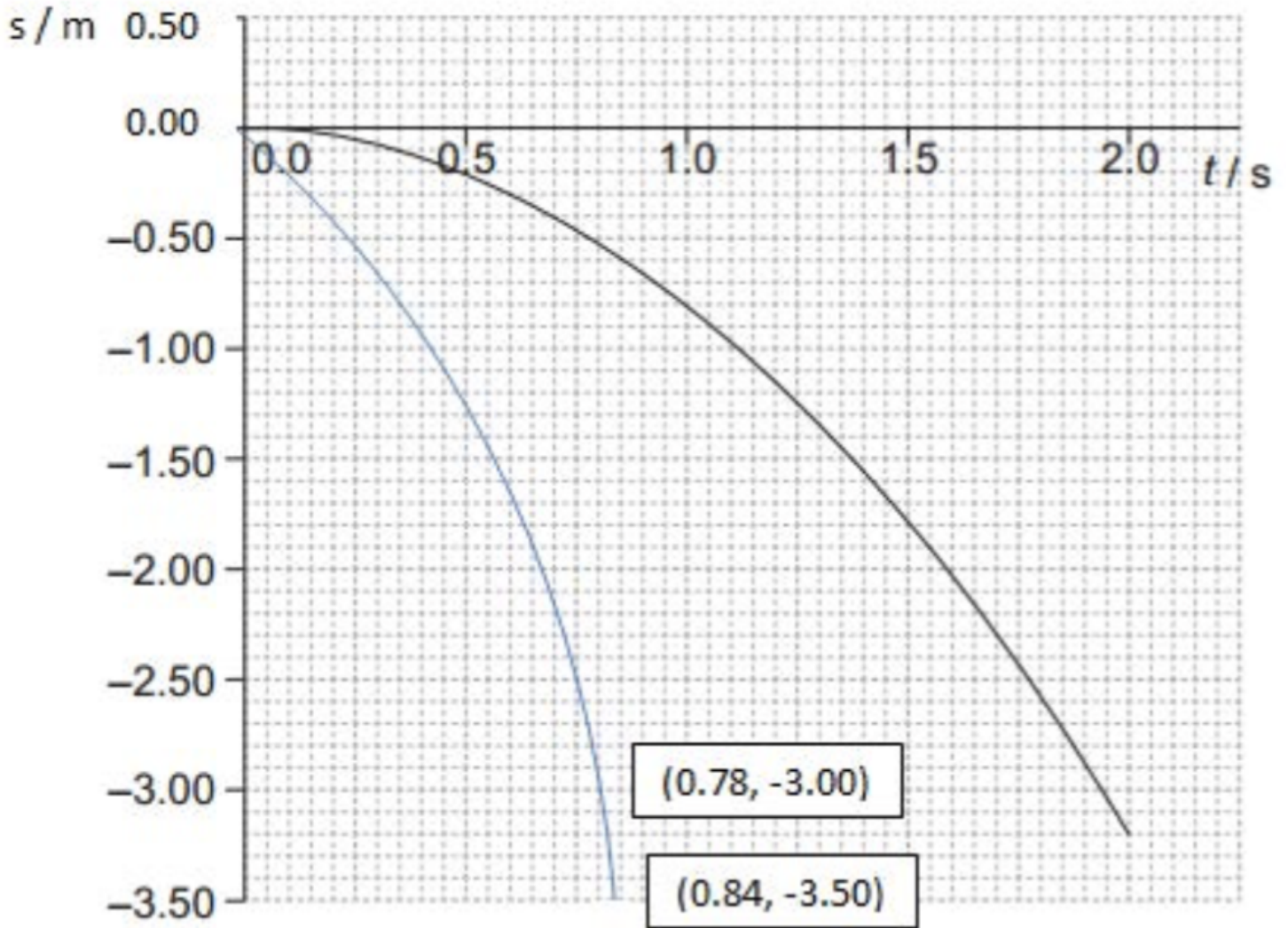

f. Ca-40 has 20 protons and 20 neutrons, Ca-47 has 20 protons and 27 neutrons / Ca-47 has 7 additional neutrons;

mention of strong/nuclear **and** coulomb/electrostatic/electromagnetic forces;

excess neutrons/too high a neutron-to-proton ratio leads to the coulomb/electrostatic' electromagnetic force being greater than the strong/nuclear force (so the nucleus is unstable);

Award [1 max] for an answer stating that Ca-47 has more neutrons so is bigger and less stable.

g. six half-lives occurred;

$$\left(\left(\frac{1}{2}\right)^6 =\right) 1.6\% \text{ remaining};$$

98.4 / 98% decayed;

h. (i)(electron) anti-neutrino / $\bar{\nu}$;

$$(ii) 46.95455 \text{ u} - (46.95241 \text{ u} + 0.00055 \text{ u}) = 0.00159 \text{ u};$$

1.48 MeV;

(iii) does not account for energy of (anti) neutrino/gamma ray photons;

Examiners report

- a. [N/A]
 - b. [N/A]
 - c. [N/A]
 - d. [N/A]
 - e. [N/A]
 - f. [N/A]
 - g. [N/A]
 - h. [N/A]
-